

Overview of Test Key Combinations

Operations	Short Press	Long Press	Sum of Pressings	Comments
TEST SMOKE ALARM (LOCAL)	1	-	1	
TEST OF ALL SMOKE ALARMS (REMOTE)	-	1	1	
HUSH SMOKE ALARM (LOCAL)	1	-	1	Only on alarm mode
HUSH OF ALL SMOKE ALARMS (REMOTE)	-	1	1	Only on alarm mode
BATTERY STATUTS CHECK	2	-	2	
SIGNAL STRENGTH TEST	1	1	2	
NETWORK INSTALLATION (CENTRAL)	2	1	3	
NETWORK INSTALLATION (PERIPHERAL)	3	-	3	

Indications Overview

Modes	Visual Indication (flashing)	Audio Signal	Comments
NORMAL OPERATION	1 Red Per Minute	None	The device operates normally
FUNCTION CHECK	1 Red Per Second	Alarm Pattern	Device Under Testing
ALARM	1 Red Per Second	Alarm Pattern	Smoke Detection
HUSH	1 Red Per 10 Seconds	None	9 minutes reduced sensitivity
ALARM MEMORY	3 Yellow Per 43 Seconds	None	Exit from alarm function
LOW BATTERY	None	1 short sound every minute	Replace the batteries
FAULT WARNING	None	3 short sounds every minute	Replace the smoke alarm

Battery and Wireless Signal Strength Tests

Flashing Number	Battery Level	Signal Strength
1	Very Low	Very Weak
2	Low	Weak
3	Medium	Medium
4	High	Strong
5	Very High	Very Strong

Recycling and Disposal

The WEEE symbol means that this product and batteries must be disposed separately from other household waste. When they reach their end of life, take them to a designated waste collection point in your area to guarantee a safe disposal or recycling. Protect the environment, human health and natural resources!

Troubleshooting

False alarm is often caused by dust or steam.

After the batteries replacement, the device performs an auto-adjusting process in 8 hours period to establish its operation. If false alarm happens within this period, it is important to clean the smoke alarm as described in maintenance paragraph.

If a smoke alarm does not perform the "Remote Device Test", perform a "Factory Reset" and reinstall it on the network. If it is far from neighboring smoke alarms, you may need to install an additional smoke alarm in between.

If a smoke alarm receives a low signal level, place it closer to its nearest smoke alarm or install a new smoke alarm in between.

Battery Replacement

1. Remove the smoke alarm the from mounting plate following Step 1 of the installation instructions.
2. Clean the device as described in maintenance paragraph.
3. Replace the old batteries by a new pair. Use recommended batteries for more reliable operation.
4. Place the smoke alarm on the mounting plate and secure it by turning it clockwise.
5. Test the correct operation of your smoke alarm as described in Device Test paragraph. If no sound is generated, the smoke alarm must be replaced immediately!

Technical Characteristics

BS-506/WL	
POWER SUPPLY	Replaceable batteries: 2x AA Lithium FR6 (L91)
BATTERY LIFE	10 years
SMOKE CONCENTRATION SENSITIVITY	0.110 dB/m
INDICATORS	Optical and Acoustic > 85dB (A) at 3 m
ALARM SILENCE FACILITY	Yes
LOW BATTERY WARNING	Yes
LOW BATTERY SILENCE FACILITY	Yes
MOUNTING LOCATION	Ceiling
INTERCONNECTABLE	Wireless
INTERCONNECTION CAPABILITY	Up to 40 Smoke alarms
OPERATIONAL FREQUENCY RANGE	868-870 MHz
TRANSMIT POWER	< 13,5 dBm
TRANSMISSION RANGE	>100m in open area (LoS)
DETECTION METHOD	Optical
DEGREES OF COVER PROTECTION	IP20
PRODUCED IN ACCORDANCE WITH	EN14604-2008, EN300220-2
OPERATION TEMPERATURE RANGE	0 to 45 °C
RELATIVE HUMIDITY	Up to 93%
CONSTRUCTION MATERIAL	ABS/PC, PC
EXTERNAL DIMENSION	Ø130 x 43 mm.
WEIGHT	185gr.
GUARANTEE	3 years (1 year for the batteries)

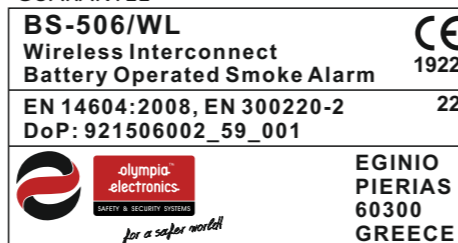

Warranty

Olympia Electronics guarantees the quality, condition and operation of the goods. The period of warranty is specified in the official catalogue of Olympia Electronics and also in the technical leaflet, which accompanies each product. This warranty ceases to exist if the buyer does not follow the technical instructions included in official documents given by Olympia Electronics or if the buyer modifies the goods provided or has any repairs or re-setting done by a third party, unless Olympia Electronics has fully agreed to them in writing. Products that have been damaged can be returned to the premises of our company for repair or replacement, as long as the warranty period is valid.

Olympia Electronics reserves the right to repair or to replace the returned goods and to or not charge the buyer depending on the reason of defection. Olympia Electronics reserves the right to charge or not the buyer the transportation cost.



72nd km. O.N.R. Thessaloniki-Katerini
P.C. 60300 P.O. Box 06 Eginio Pierias Greece

www.olympia-electronics.com
info@olympia-electronics.gr



BS-506/WL

WIRELESS INTERCONNECT BATTERY OPERATED SMOKE ALARM



Thank you for your trust in our products
Olympia Electronics - European manufacturer

Package Contents

1	Smoke alarm
2	AA Batteries (installed)
1	Mounting accessories
1	Manual

General

The BS-506/WL is a wireless interconnect battery operated smoke alarm with an optical sensor. It has the ability to connect wirelessly without the need of additional equipment to create a network of smoke alarms. Before installation, always consult local regulations for smoke alarms.

CAUTION!!

- To prevent injury, the device must be securely attached to the ceiling in accordance with the installation instructions.
- Batteries should be protected from excessive heat, such as direct light beams or fire.
- Do not paint or cover the smoke alarm.
- Do not install the smoke alarm in direct sunlight. Keep at least 0.5m from light sources.
- Do not install the smoke alarm close to ventilation points.
- Do not install the smoke alarm in leisure accommodation vehicles
- Consult the manufacturer's advice if the device doesn't work properly.
- Due to the loudness of the alarm, make sure that you always stand at arm's length distance from the unit when you are testing.
- Do not charge batteries
- Do not mix new and used batteries or batteries of different types or brands
- Exhausted batteries should be immediately removed from equipment and properly disposed of
- Do not dismantle batteries
- Do not deform batteries
- A lithium battery with a damaged container should not be exposed to water
- Store unused batteries in their original packaging away from metal objects. If already unpacked, do not mix or jumble batteries
- Replace all batteries of a set at the same time.
- Clean the battery contacts and also those of the equipment prior to battery installation
- Ensure that the batteries are installed correctly with regard to polarity (+ and -)
- Remove exhausted batteries promptly

Device Test (Local)

The device is checked by briefly pressing the test button. If the device works properly, it will produce a loud sound. When the sound stops, the device will enter hush mode. After 9 minutes it returns to normal operation.

Remote Device Test

Wireless communication allows to perform device test for all smoke alarms of a network by giving command from one device only. To start the test, long press the test button from any network smoke alarm once. This smoke alarm performs a check such as described in the section "Device Test (local)" and transmits the test command to all smoke alarms. The network smoke alarms will perform the test and produce a loud sound (not necessarily at the same time).

Low Battery Mode

If the battery's level is low, the siren will sound as a short pulse every minute, it will continue until the batteries are replaced. The sound of the battery low level can be muted by pressing the TEST Button briefly. The Red LED will turn on to indicate the low battery condition. After the TEST button is released, the unit enters in Low Battery Hush mode and the device is silenced for 8 hours. After 8 hours, the audible indication will resume. The activation of the TEST button will also initiate the 9 minutes Hush mode.

Manual Battery Test

You can test the battery level by pressing the test button 2 short times. The number of flashes that will follow, will show the battery level according to indication table on page 4.

Wireless Link Test

The BS-506/WL provides wireless signal strength test with power level indication. First, perform the "Remote Device Test" function on the neighboring smoke alarm on the same network. Then on the smoke alarm under test, press the test key 1-time momentarily and 1-time long press. The number of flashes of the green LED that will follow represents the signal strength level of the communication between them, according to the indication table on page 4.

Alarm mode

If a smoke alarm detects smoke, it immediately goes into alarm mode. In addition, it transmits the alarm signal to the other smoke alarms in the network, where they go into remote alarm mode. When the original smoke alarm ceases to detect smoke, it shall transmit an end-of-alarm signal and the remaining smoke alarms will return to the quiescent state. During an alarm, the user can silence the devices with the 'Hush' and 'Remote Hush' functions.

Hush mode

When the device is in alarm mode, Hush can be initiated with 1 short press of the test button. Hush is activated and the siren is silenced. The duration of Hush is 9 minutes and the Red LED flashes faster. Afterward, the device returns to normal operation. While in Hush, the sensitivity of the device is reduced and a higher concentration of smoke is required to put it back on alarm. It is possible to cancel the Hush mode by repeating the short press of the test button.

Remote Hush

When the network smoke alarms are in an alarm state, a device may issue a hush command to all of them; To activate the hush command to the entire network, long press the test button from any smoke alarm.

Note: If a smoke alarm in hush mode detects the presence of smoke in an ultra-high concentration, then the entire network will return to alarm mode.

Alarm Memory

The Alarm Memory allows easy identification of any unit that had previously been in Alarm. When a smoke alarm exits an Alarm mode, the Yellow LED flashes three times and this pattern repeats every minute. This visual indication will stop after 24 hours. The user will still be able to identify a unit that had previously been in Alarm, by pressing the TEST button. The horn will sound in short pulses and the Alarm memory will reset. The initial 24 hour visual indication is not displayed when a low battery condition exists.

Fault Warning

When the smoke alarm is not functioning properly, it will turn into the Fault warning mode and will produce three short acoustic signals every minute. Try cleaning the smoke alarm (see paragraph maintenance) otherwise replace it!

Smoke alarms Network

Smoke alarms with factory default settings do not belong to a private network and communicate with all smoke alarms that also retain their factory settings. It is possible to group them into networks of smoke alarms that communicate with each other, preventing the interaction of smoke alarms belonging to different locations only. Refer to the 'Network Installation Guide' section.

Network Installation Guide

1. Make sure that the smoke alarms have their batteries installed correctly. Consider a smoke alarm to be the central network installation device. The peripheral devices must be installed one by one on the network of the main one.
2. On the central device, press the test button 2 times momentarily and the 3rd time long. When you release it, the green LED will flash, indicating that the installation process has started.
3. On the peripheral device press the test button momentarily 3 times, you will notice rapid flashes of the green LED that will stop when it is installed on the network. For each new device that is installed, you will observe a prolonged flash of the green LED on the central device .
4. Repeat step 3 for each peripheral device you want to install on the network.
5. When all devices are installed, wait for the central device to stop flashing the green LED. Perform a network check as described in the "Remote Device Test" section. If all devices respond then your network has been successfully created. Otherwise, see the "Troubleshooting" section.
6. You can add new peripheral devices to the host device network in the future by repeating steps 2 to 5. For this purpose it is recommended that you have noted the central device.

Reset to factory settings

The function is provided in case where the network settings on a smoke alarm need to be initialized. This may be desirable when you want to install a smoke alarm on another network or when you want to change the role of a device, e.g. from a peripheral device to a host device or vice versa.

1. Remove one of the two batteries.
2. Press and hold the test button.
3. With the button pressed, replace the battery you removed.
4. Wait five seconds and release the button. The green led flash rapidly four times.

Maintenance

- Test the smoke alarm weekly for correct operation by using the Device Test facility. If the smoke alarm functions correctly, it will generate a loud beep otherwise must be replaced immediately!
- Clean the smoke alarm once per month to remove dirt, dust or debris.
- Use a vacuum cleaner with a soft brush and clean all sides and covers of the smoke alarm. Do not remove the top cover of the smoke alarm to clean it inside.
- Do not attempt to repair this smoke alarm. If the smoke alarm shows a damage it must be replaced!
- In accordance with EN14604 standard, is recommended to replace the device after 10 years of operation.

Installation instructions

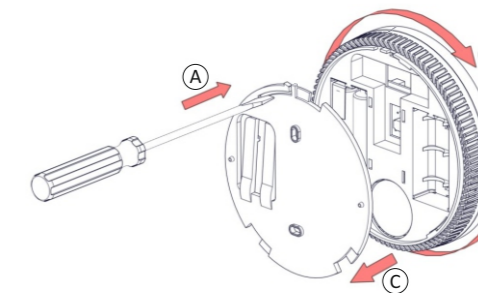

1

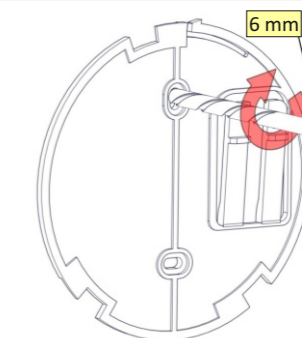

2

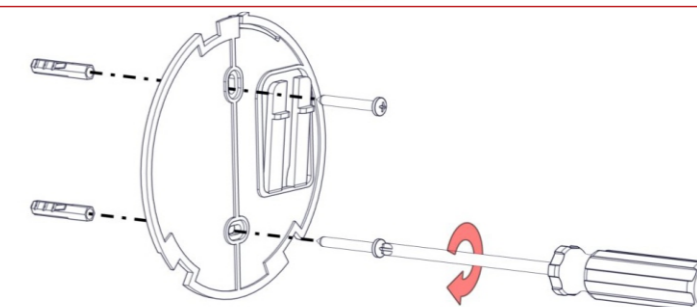

3

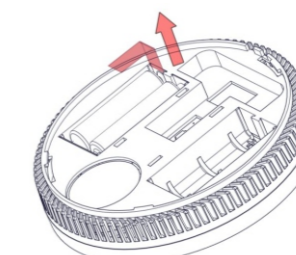

4

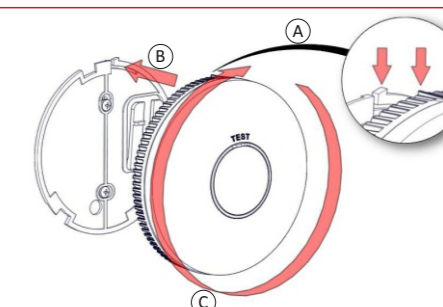

5

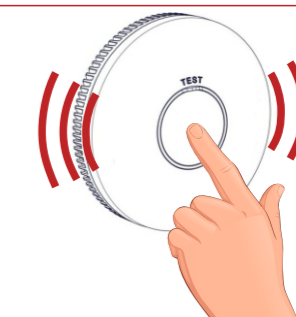

6

NOTE!!!

If no sound is generated, the smoke alarm is not functioning properly and should not be used!

6