

N1 No	Switch setting [1-2-3-4-5]	Frequency	Pattern	Rate	Main application	Sound level 1		Sound level 2		Sound level 3		Sound level 4	
						dB (A)	mA (Flash 0.5Hz)	dB (A)	mA (Flash 0.5Hz)	dB (A)	mA (Flash 0.5Hz)	dB (A)	mA (Flash 0.5Hz)
1	0-0-0-0-0	970	Continuous	Steady	PFEER toxic gas	92	18	97	20	103	30	104	35
2	1-0-0-0-0	970	Intermittent	0.5Hz (1s On/1s Off)	PFEER alert	92	18	97	19	103	23	104	26
3	0-1-0-0-0	1200-500	Sweep	1s sweep	German fire (DIN 33 404)	92	18	97	20	102	26	106	47
4	1-1-0-0-0	500-1200	Slow whoop	3s sweep, 0.5 sec silence	Dutch fire (NEN 2575) (*)	92	18	98	19	103	25	107	43
5	0-1-0-0-0	800 & 970	Alternating	1Hz (500ms-500ms)	BS Fire	93	18	97	19	103	28	105	39
6	1-1-0-0-0	2850	Intermittent	1Hz (0.5s On/0.5s Off)	General purpose	93	18	97	18	106	20	104	26
7	0-1-0-0-0	970	Intermittent	3x500ms pulsed, 1.5 sec silence	ISO 8201	70	17	97	18	103	21	104	24
8	1-1-0-0-0	2850	Intermittent	3x500ms pulsed, 1.5 sec silence		93	18	97	19	100	20	104	24
9	0-0-0-1-0	800-970	Sweep	7Hz	BS Fire	92	17	97	19	102	28	103	40
10	0-0-0-1-0	800-970	Sweep	1Hz	BS Fire (*)	92	18	102	29	102	29	100	40
11	0-1-0-1-0	2850	Continuous	Steady	General Purpose	94	19	100	19	102	23	105	36
12	1-1-0-1-0	2400-2850	Sweep	7Hz	General Purpose	89	19	102	21	97	25	100	36
13	0-1-0-1-0	2400-2850	Sweep	1Hz	General Purpose	91	19	102	21	99	24	102	34
14	0-1-0-1-0	2400-2850	Alternating	2Hz (250ms-250ms)	General Purpose	93	18	102	22	101	22	104	33
15	0-1-0-1-0	970	Intermittent	0.8Hz (250ms On/1s Off)	General Purpose	72	18	100	18	97	19	99	22
16	1-1-0-1-0	554 & 440	Alternating	100ms-400ms	General Purpose	89	18	94	19	102	26	105	49
17	0-0-0-1-1	660	Intermittent	3.3Hz (150ms On/150ms Off)	French fire (NFS 32-001)	80	17	100	18	111	90	92	31
18	1-0-0-1-1	660	Intermittent	0.28Hz (1.8s On/1.8s Off)	Swedish (Air Raid)	91	18	103	18	101	23	103	35
19	0-1-0-1-1	660	Intermittent	0.05Hz (6.5s On/13s Off)	Swedish (Local warning)	91	18	93	18	104	20	103	24
20	1-1-0-1-1	554 & 440	Alternating	0.5Hz (1s On/1s Off)	Swedish (Pre-mess)	89	18	94	19	103	26	106	50
21	0-1-0-1-1	660	Intermittent	1Hz (500ms-500ms)	Swedish (Turn out)	90	17	100	19	101	22	103	32
22	1-0-1-0-1	2850	Intermittent	4Hz (150ms On/100ms Off)	Swedish general purpose	85	19	111	89	19	12	94	27
23	0-1-0-1-1	800-970	Sweep	50Hz	Pelican crossing	92	18	97	19	102	28	104	41
24	1-1-1-0-1	2400-2850	Sweep	50Hz	BS Fire	90	19	95	21	14	98	24	100
25	0-0-0-1-1	970	Intermittent	3x500ms pulsed, 1.5s silence, then repeat	General Purpose	92	17	100	19	102	24	103	29
26	1-0-0-1-1	970	Intermittent	3x500ms pulsed, 2 tones, 1.5s silence, then repeat	ISO 8201	91	17	95	18	10	103	21	105
27	0-1-0-1-1	800 & 970	Alternating	2Hz (250ms-250ms)	BS Fire	92	18	100	19	103	27	105	39
28	1-1-0-1-1	990 & 650	Alternating	2Hz (250ms-250ms)	BS Fire	92	19	97	20	102	24	106	40
29	0-0-1-1-1	510 & 610	Alternating	2Hz (250ms-250ms)	BS Fire	91	18	100	21	104	29	107	52
30	1-0-1-1-1	300-1200	Sweep	1Hz	General Purpose	91	17	100	19	102	25	105	50
31	0-1-1-1-1	510 & 610	Alternating	1Hz (500ms-500ms)	BS Fire	91	17	100	19	104	29	107	51
32	1-1-1-1-1	150-1000	Sweep up, continuous, slow whoop	10s sweep 150-1000, 40s continuous, 10s sweep 1000-150	BS Fire	92	18	100	22	14	106	107	45
33													

Technical Characteristics

BS-532/WP	
MAIN VOLTAGE	18-30V
ALARM CONSUMPTION	18 to 51mA
MAXIMUM SOUND LEVEL IN 1 METER	107dB
BEACON	1 Power LED
ENVIRONMENTAL TYPE	Type B
MOUNTING	Wall mounted
MOUNTING HEIGHT (x)	2.4 meters max
COVER AREA CODE	O-2.4-2.4-4.8
COVER AREA	27.7m ³ maximum
FLASHING RATE	Adjustable to 1 Hz or 0.5 Hz
FLASHING COLOUR	White
DEGREES OF COVER PROTECTION	IP65
PRODUCED IN ACCORDANCE WITH	EN 54-3, EN 54-23
OPERATING TEMPERATURE RANGE	-25 to 70 °C
RELATIVE HUMIDITY	Up to 95%
CONSTRUCTION MATERIALS	ABS/PC,PC
EXTERNAL DIMENSIONS	127x137x82 mm
TYPICAL WEIGHT	306 gr.
GUARANTEE	2 years

Warranty

Olympia Electronics guarantees the quality, condition and operation of the goods. The period of warranty is specified in the official catalogue of Olympia Electronics and also in the technical leaflet, which accompanies each product. This warranty ceases to exist if the buyer does not follow the technical instructions included in official documents given by Olympia Electronics or if the buyer modifies the goods provided or has any repairs or re-setting done by a third party, unless Olympia Electronics has fully agreed to them in writing. Products that have been damaged can be returned to the premises of our company for repair or replacement, as long as the warranty period is valid.

Olympia Electronics reserves the right to repair or to replace the returned goods and to or not charge the buyer depending on the reason of deflection. Olympia Electronics reserves the right to charge or not the buyer the transportation cost.



72nd km. O.N.R. Thessaloniki-Katerini
P.C. 60300 P.O. Box 06 Eginio Pierias Greece
www.olympia-electronics.com
info@olympia-electronics.gr



European
manufacturers



BS-532/WP

WATERPROOF SOUNDER WITH BEACON



Thank you for your trust in our products
Olympia Electronics - European manufacturer

Package Contents

- 1 Sounder
- 1 Mounting Accessories
- 1 Manual

General

This device is used as an indication of a fire panel that provides a warning audio signal from the siren and visual indication using the beacon. The loudness and the luminous signal it produces covers an area of several square meters. It is compatible with any conventional panel.

Dimensional drawing (mm)

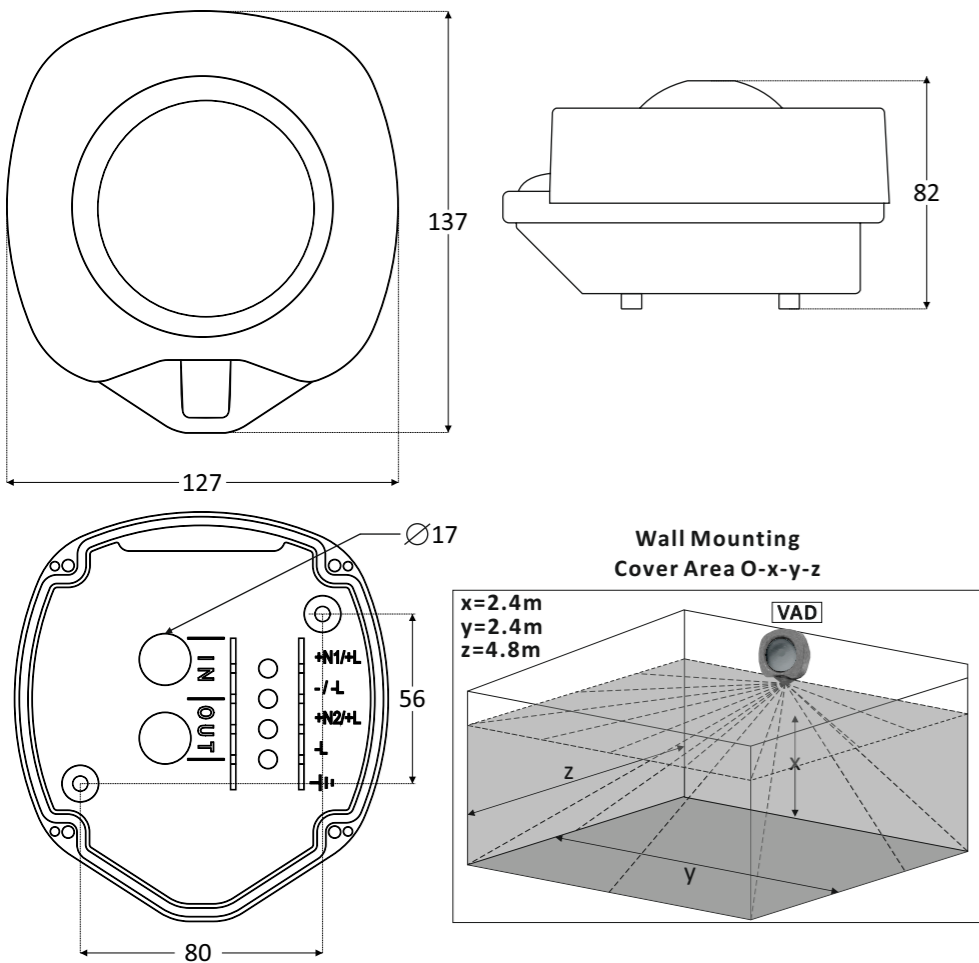

Installation Instructions

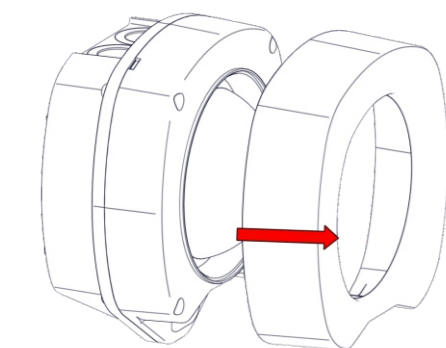

Remove the front plastic cover.

1

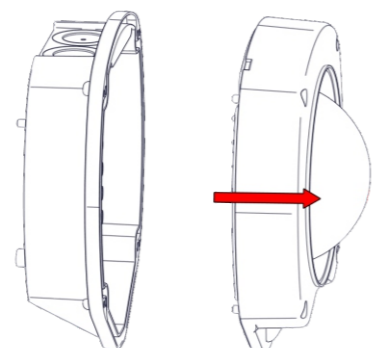

Remove the second plastic from its base.

2

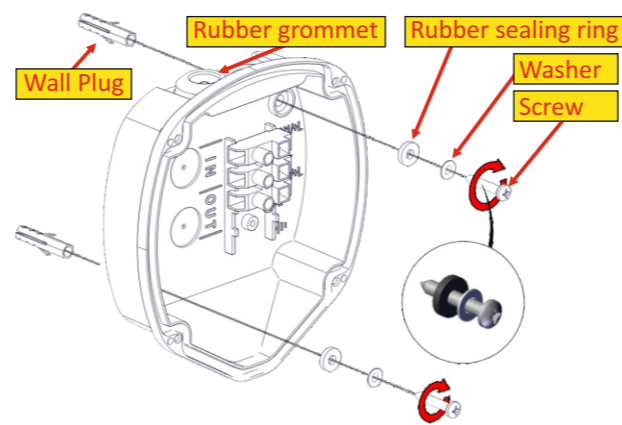

Drill the holes needed to pass the connection cables. Place the cable rubber grommets and open a hole to the center with a small screwdriver. Pass the connection cables through the rubber grommets. Use the supplied mounting accessories to place the base of the siren in height up to 2.4 meters from the ground. **CAUTION!! Make sure that the base of the siren is installed in the correct orientation.**

3

Example connection diagram with BS-1638 fire detection panel of Olympia Electronics

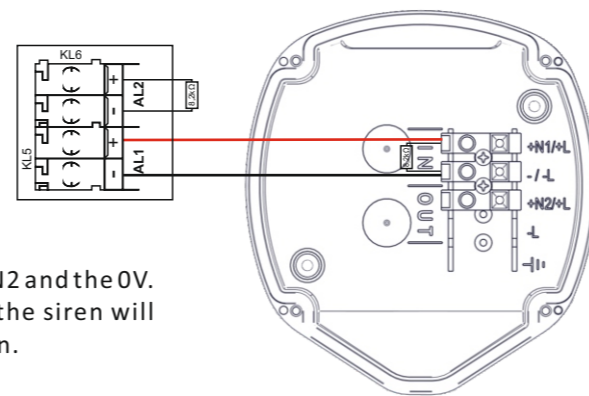

Connect supply either to N1 or N2 and the 0V. Depending on the connection the siren will sound with the matching pattern.

4

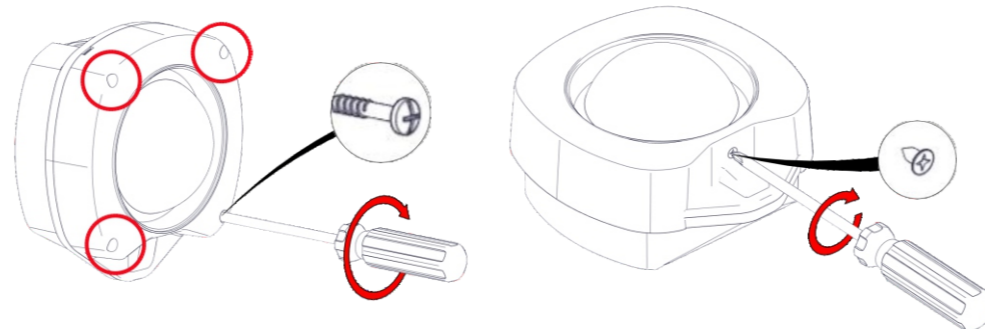

Replace the plastic cover and fasten it with the four including screws.

5

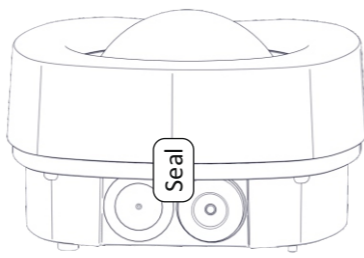

Replace the plastic cover and fasten it with the including red screw.

6

NOTE!!! After finishing the installation, place the sticker SEAL as shown in the picture above.

6

Visual indication of the siren with power LED.

Test the operation of the device through the panel after the installation.
UID: In every device there is a double sticker with the UID (Unique Identifier) number.
This number is unique for each device.

Adjusting the siren & beacon

DIP switches for siren and beacon settings.

Supply terminals.

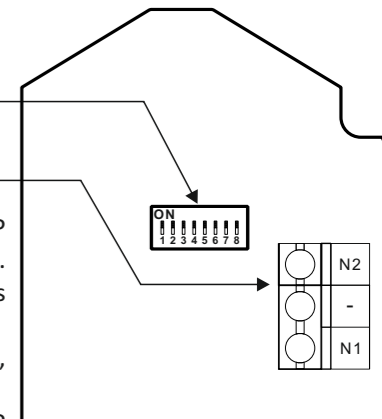

- To **adjust the type of the sound indication** use DIP switches 1 to 5, according to Table 4 and Table 5. Depending on the input from which the device is powered.
- To **adjust the sound level** use DIP switches 6 to 7, according to Table 1.
- To **adjust the frequency of the flashing LED** use DIP switch 8 according to Table 2.

Note: The siren can be supplied from the input N1 or N2. In case it is supplied from both inputs then N1 has priority. Depending on the connection you will choose and the setting of DIP switches 1 to 5 the corresponding pattern will sound. By connecting the siren to input N1 and configuring DIP switches 1 to 5 the pattern that will sound is shown in Table 5. By connecting the siren to input N2 and configuring DIP switches 1 to 5 the pattern that will sound is shown in Table 4. The difference in the patterns between N1 and N2 allows the device to be used both as a pre-alarm and alarm indication.

Sound level No	Switch setting [6-7]
1	0-0
2	1-0
3	0-1
4	1-1

Light temporal pattern and frequency	Switch setting [8]
170 ms pulse at 1 Hz	0
170 ms pulse at 0.5 Hz	1

Angle of measurement	dB(A) at 1m at Sound level 4
15	93
45	99
75	103
105	103
135	101
165	94

N2 A/A	Switch setting [1-2-3-4-5]	Pattern match with Table 1 No	N2 A/A	Switch setting [1-2-3-4-5]	Pattern match with Table 1 No	N2 A/A	Switch setting [1-2-3-4-5]	Pattern match with Table 1 No
1	0-0-0-0-0	1	12	1-1-0-1-0	11	23	0-1-1-0-1	1
2	1-0-0-0-0	1	13	0-0-1-1-0	11	24	1-1-1-0-1	11
3	0-1-0-0-0	1	14	1-0-1-1-0	11	25	0-0-0-1-1	25
4	1-1-0-0-0	1	15	0-1-1-1-0	1	26	1-0-0-1-1	26
5	0-0-1-0-0	1	16	1-1-1-1-0	1	27	0-1-0-1-1	1
6	1-0-1-0-0	11	17	0-0-0-0-1	17	28	1-1-0-1-1	2
7	0-1-1-0-0	7	18	1-0-0-0-1	18	29	0-0-1-1-1	1
8	1-1-1-0-0	8	19	0-1-0-0-1	19	30	1-0-1-1-1	1
9	0-0-0-1-0	1	20	1-1-0-0-1	20	31	0-1-1-1-1	1
10	1-0-0-1-0	1	21	0-0-1-0-1	21	32	1-1-1-1-1	11
11	0-1-0-1-0	1	22	1-0-1-0-1	1			