

## Package Contents

- 1 Luminaire with track adapter
- 1 Set of Pictograms
- 1 Manual
- 2 Labels for 3 & 8 hours duration

## General

### Manual Operational Test

The operational test is initiated by briefly pressing the TEST button. This will test the light source and the emergency circuit of the device. The manual operational test can only be conducted when both the mains power supply and the battery are connected. During the test, the LAMP FAULT LED will start blinking. Ensure that the battery has sufficient charge. The test will last for 3 seconds.

### Manual Autonomy Test

The manual autonomy test is initiated by pressing and holding the TEST button for 5-10 seconds. For this test, the mains power supply must be connected, and the battery must be fully charged. The luminaire will enter emergency mode, the CHARGE LED will turn off, and the BATTERY FAULT LED will start blinking. The test will run for the duration of the luminaire's stated autonomy. If the autonomy is lower than the nominal value by the end of the test, the BATTERY FAULT LED will light up, indicating that the battery needs to be replaced. If the result is satisfactory, the luminaire will enter charging mode, and the CHARGE LED will continue to blink until the battery is fully charged.

### Automatic Operational Test

The automatic operational test includes all functions of the Manual Operational Test and is performed automatically every 15 days, lasting for 3 seconds.

### Automatic Autonomy Test

The Automatic Autonomy Test is conducted every 6 months and tests the device's backup operation and emergency duration. This test includes all the functions of the Manual Autonomy Test.

### ATTENTION!

1. Installation, maintenance, and testing must only be performed by authorized personnel.
2. Always use round mains cables with a diameter of 5-10mm (e.g., H05RN-F type 2x1mm<sup>2</sup> or other cables with equivalent or better mechanical and electrical properties). ATTENTION: The cable must not be deformed in any way. This is essential for maintaining the IP rating.
3. The device must be connected to the mains power supply via a circuit breaker suitable for the total power load of the line.
4. In the case of battery replacement, ensure that the new battery is of the same type and is installed by the manufacturer or a qualified professional.
5. If the device is not in use for more than 2 months, disconnect the battery by removing the battery connector.
6. If the luminaire fails to meet the rated duration of operation after the corresponding recharge period, the battery must be replaced.
7. Batteries must not be disposed of in regular trash bins. They must be discarded at battery recycling points only. Do not incinerate.

### Connectors

- CN5: Non-user connector
- CN9: Module port
- CN8: Recess LED port

- CN10: Power connector
- CN6 & CN7: Battery connectors
- CN11: Communication port

## Indications LED Status

CHARGE (green)	LAMP FAULT (red)	BATT. FAULT (yellow)	Description
●	∅	∅	Charging
●	∅	∅	Fully charged
○	∅	∅	Battery fault or emergency mode
∅	●	∅	Operational test
∅	●	∅	Light source fault
∅	∅	●	Autonomy test
∅	∅	●	Duration fault
<b>Note:</b>			● Permanently ON    ● Blink    ○ Off    ∅ Indifferent

## Installation Instructions

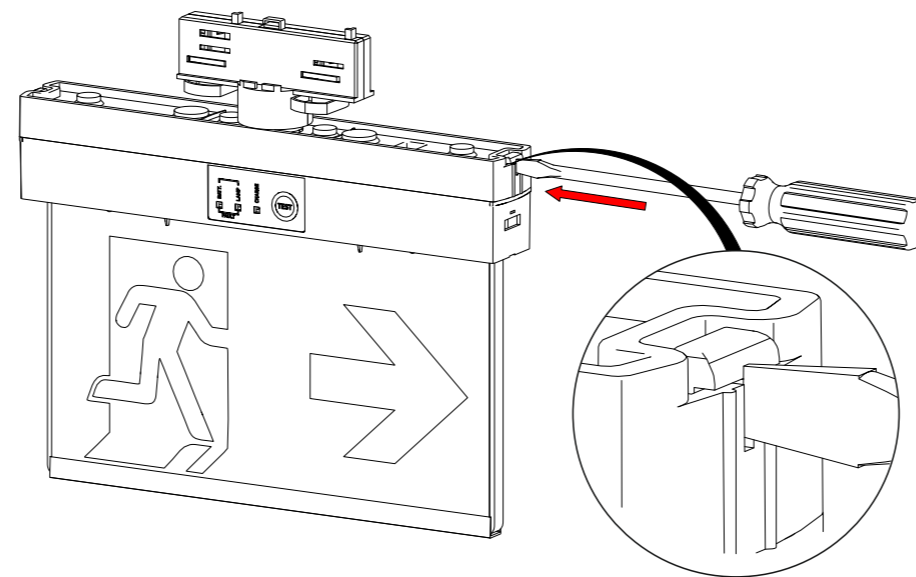

Place a flat-blade screwdriver at the marked position and push it until it unlocks. Gently pull up the top cover and remove it.

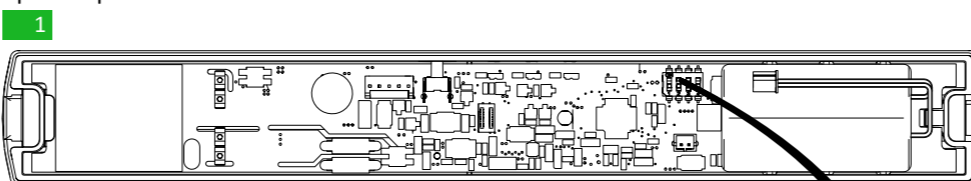

### Dip Switch Positions (DS1)

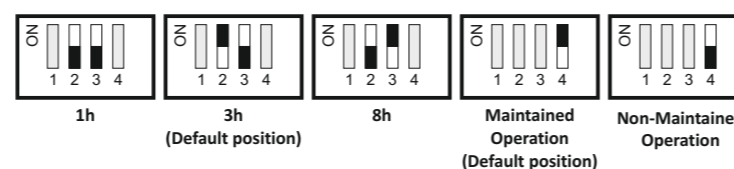

### Autonomy Duration Selection

The user can select one of the three available minimum autonomy durations: 1 hour, 3 hours, or 8 hours. **Important:** The selection must be made while the luminaire is disconnected from both AC and battery power supplies. The autonomy duration is configured via switches 2 and 3 of DIP switch DS1. Switch 1 is not used.

### Changing the Operating Mode

The operating mode (maintained or non-maintained) is set using switch 4 of DIP switch DS1.

- For maintained operation, switch 4 must be in the ON position.
- For non-maintained operation, switch 4 must be in the OFF position.

### Technical Label Installation

Two additional labels are included in the package: One for 1-hour duration (marked "60") One for 8-hour duration (marked "480"). Depending on the selected autonomy duration, the installer must cover the default 3-hour (marked "180") label with the one that corresponds to the chosen setting.

**Note:** Pay careful attention to the orientation of the replacement label during installation.

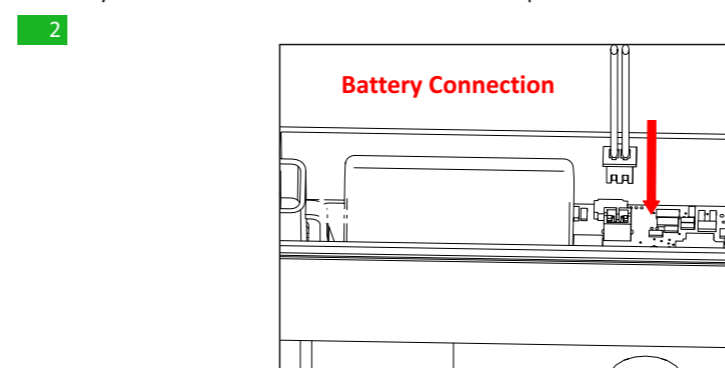

Connect the battery cable to its respective connector on the PCB.

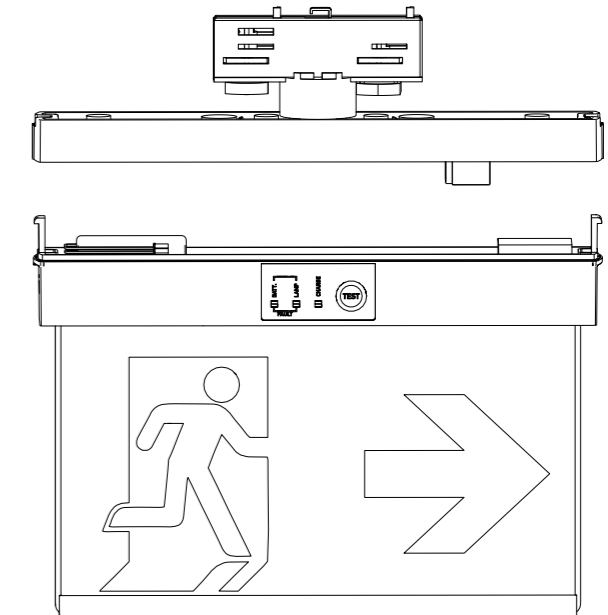

Pay attention to the orientation of the plastic parts during assembly.

**Note:** The power connection is already attached to the luminaire. The luminaire is ready for use once it is connected to the track system.

## Installation to the track system

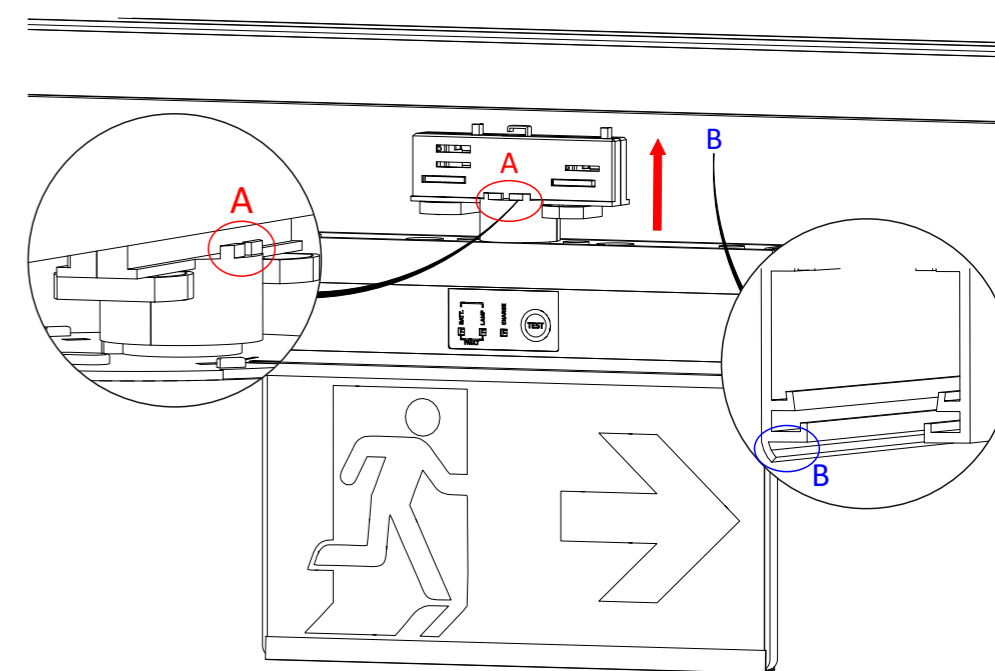

Install the luminaire onto the track system. Ensure that the two plastic switches are expanded. Make sure that point A of the adapter and point B of the track are facing opposite directions to ensure correct installation orientation.

**Note:** The adapter is only compatible with 4-phase track systems.

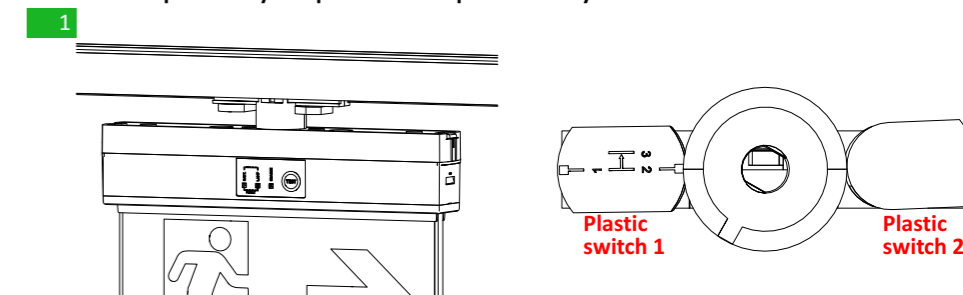

Rotate the two plastic switches to lock the adapter onto the track.

**Note:** Plastic switch 2 is used solely to secure the adapter to the track, while plastic switch 1 is used to select the phase on which the luminaire will operate.

### NOTE!!

After finishing the installation you must power the luminaire for at least 24 hours in order to completely charge the battery. The rated autonomy duration can be achieved after that time.

## Pictogram Replacement

### KLD-22 & KLD-30

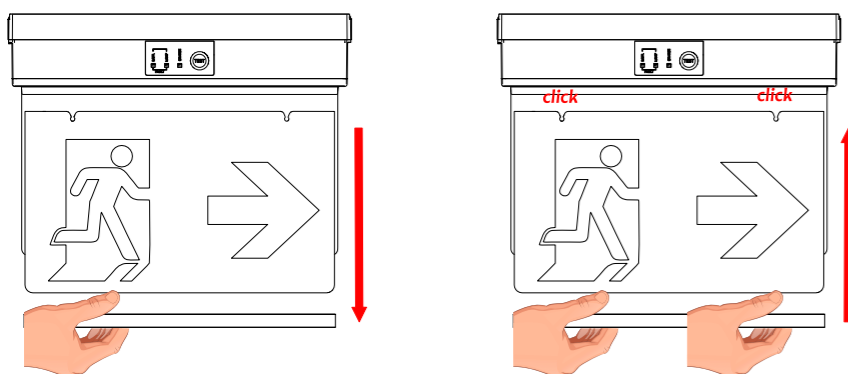

To replace the pictograms on models KLD-22 and KLD-30, follow these steps:

- Carefully remove the plastic retaining clip.
- Remove the two existing pictograms from both sides of the luminaire.
- Install the two desired pictograms in the same positions and push upwards until you hear a "click".
- Reattach the plastic retaining clip to secure the new pictograms in place.

### KLR-20

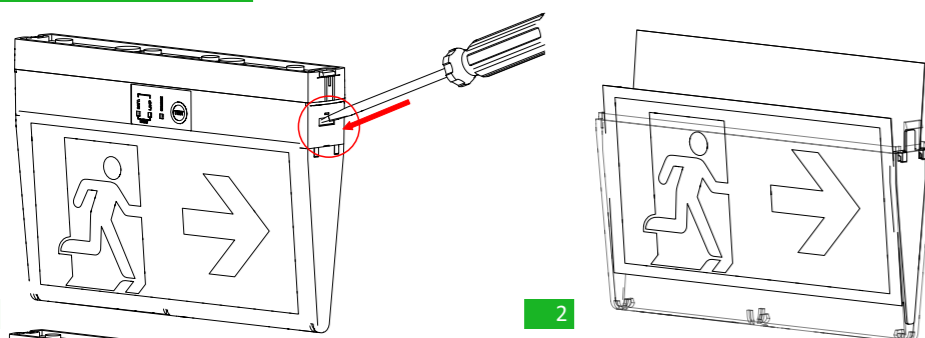

To replace the pictograms on the KLR-20 model, follow these steps:

- Insert a flat-blade screwdriver into the marked position and push gently until the mechanism unlocks. Carefully remove the plastic part containing the pictograms.
- Remove the two existing pictograms from both sides of the luminaire and install the new desired pictograms in the same positions.
- Reattach the plastic part to the luminaire and push upwards until you hear a "click".

## Battery Replacement

It can be done only by a competent person and after the mains interruption.

- Disconnect mains.
- Carefully remove the luminaire from the top cover. (Step 1 of installation procedure)
- Disconnect the battery and install a new one of the same type and characteristics.
- Refit the luminaire to the top cover.

### ATTENTION

The light source of this luminaire is not user replaceable. When the light source reaches its end of life the whole luminaire shall be replaced.

### NOTE: LED= Light Emitting Diode

#### LABELING EXPLANATION:

X: Self contained

1: Maintained/Non maintained (\*)

A: Including test device

E: With non-replacable lamp(s) and/or battery

F: Automatic test gear with IEC 61347-2-7 denoted EL-T

G: Internally illuminated safety sign

60: 1 hour duration

180: 3 hours duration

480: 8 hours duration

X1AEFG180

(\*) Maintained operation: The luminaire lights its illumination source, when it is powered by the mains power supply or not.

Non Maintained operation: The luminaire lights its illumination source, only in mains power supply's failure.

## Technical Characteristics

	KLD-30/ST/TL KLD-30/ST/BLACK/TL	KLD-22/ST/TL KLD-22/ST/BLACK/TL	KLR-20/ST/TL KLR-20/ST/BLACK/TL
OPERATION VOLTAGE	220-240V AC / 50-60Hz		
MAXIMUM POWER CONSUMPTION	3.9W / 4.4VA		
SUPPLY CURRENT	20mA		
U-OUT	70V		
Prated	1.5W		
Irated	130mA		
MAX OPEN CIRCUIT VOLTAGE	39V DC		
EMERGENCY OUTPUT FACTOR (EoFx)	1h: 3.4, 3h: 1.4, 8h: 0.2		
WIRE CROSS SECTION	0.08mm <sup>2</sup> - 1.5mm <sup>2</sup>		
MINIMUM POWER FACTOR	0.87		
BATTERY (Ni-MH)	3.6V/1.5Ah		
INSULATION BETWEEN SUPPLY & CONTROL TERMINALS	Basic Insulation		
INSULATION BETWEEN SUPPLY & BATTERY CIRCUIT	Basic Insulation		
BATTERY PROTECTION	Deep discharge and overcharge protection The control gear will recharge the battery normally after the test of 22.3		
MIN MAX. DISCHARGE VOLTAGE	3 - 4.5V		
MIN MAX. DISCHARGE CURRENT	1h (400-690mA), 3h (190-295mA), 8h (55-95mA)		
MIN MAX. CHARGE CURRENT	20 - 120mA		
TRICKLE CHARGE VOLTAGE/CURRENT	4.4V / 40mA		
MAX CHARGE VOLTAGE	4.9V		
INDICATIONS	LED Charge, Lamp Fault LED, Battery Fault LED / Test Button		
CHARGE TIME	24 hours		
MINIMUM DURATION	1, 3, 8 hours manually selected (default 3h)		
LIGHT SOURCE / OUTPUT MODE	LED / CONSTANT CURRENT		
LIGHT SOURCE LUMINOUS FLUX MAINS	80lm		
LIGHT SOURCE LUMINOUS FLUX EMERGENCY	1h: 250lm, 3h: 110lm, 8h: 15lm		
DEGREES OF COVER PROTECTION	IP54		
PRODUCED IN ACCORDANCE WITH	EN 60598-1, EN 60598-2-22, EN 55015, EN 61547, EN 61000-3-2, EN 61000-3-3		
OPERATION TEMPERATURE RANGE	5 to 40 °C		
CONTROL GEAR MAX.TEMPERATURE: tc	58 °C at BR1		
RELATIVE HUMIDITY	Up to 95%		
CONSTRUCTION MATERIAL	PC, Acrylic Plate	PC	
COLOR	White or Black		
EXTERNAL DIMENSION W/O ADAPTER (L x W x H)	310x35x216mm	260x35x180mm	260x35x170mm
WEIGHT	1050 g	820 g	620 g
GUARANTEE	3 years (1 year for the battery)		
CONTROL GEAR WITH AUTOMATIC TEST FUNCTION	<b>EL-T</b>		
<b>LED Characteristics</b>			
MANUFACTURER	Olympia Electronics S.A.		
MODEL NUMBER	2711195		
VOLTAGE RANGE	11.2-13.2V DC		
NOMINAL POWER	0.72		
CONNECTIONS	Built-in main board		
TEMPERATURE (tc)	45°C max. across the board		

## Warranty



72nd km. O.N.R. Thessaloniki-Katerini  
P.C. 60300 P.O. Box 06 Eginio Pierias Greece

[www.olympia-electronics.com](http://www.olympia-electronics.com)  
[info@olympia-electronics.com](mailto:info@olympia-electronics.com)



**SELF TESTING MAINTAINED  
EMERGENCY ILLUMINATION SIGNS  
FOR TRACK LIGHT SYSTEM**



**Thank you for your trust in our products  
Olympia Electronics - European manufacturer**