

ADDRESSABLE SELF TESTING MAINTAINED EMERGENCY LUMINAIRE



TECHNICAL CHARACTERISTICS (for LED MODULE Specs. see page 2)

	GR-2100/ST/M/ADR	GR-2110/ST/M/ADR
OPERATION VOLTAGE	220-240V AC/50-60Hz	
MAXIMUM POWER CONSUMPTION	3.3W / 3.6VA	
BATTERY (Ni-Cd)	3.6V/600mAh	3.6V/1.5Ah
INDICATIONS - CONTROLS	Battery and charge Fault indication LEDs, TEST button	
CHARGING TIME	16 h	24 h
MINIMUM AUTONOMY DURATION	1.5 h	3 h
ILLUMINATION SOURCE	12 White LEDs	
ILLUMINATION (230V AC / emergency)	100lm / 100lm	
VEWING DISTANCE	22m	
DEGREES OF COVER PROTECTION	IP30	
PRODUCED IN ACCORDANCE WITH	EN 60598-1, EN 60598-2-22, EN 55015, EN 61547, EN 61000-3-2, EN 61000-3-3	
OPERATION TEMPERATURE RANGE	5 to 40 °C	
RELATIVE HUMIDITY	up to 95%	
CONSTRUCTION MATERIALS	ABS/PC,PC	
EXTERNAL DIMENSIONS	292 x 111 x 54 mm	
TYPICAL WEIGHT	476gr.	557gr.
GUARANTEE	3 years (1 year for the battery)	

Thank you for your trust in our products Olympia Electronics - European manufacturer

GENERAL

These luminaires are used indoors (ta 40°C) where emergency light is needed.

Each luminaire must be permanently connected to mains power supply. In normal operation the illumination LEDs are lit as well as the green indicating charge LEDs when the battery is charging. In case of a mains power supply failure, the luminaire enters in emergency mode and will light automatically. When the mains power supply is restored the device turns to normal operation.

INSTALLATION

To install the luminaire follow the installation instructions on page 3.

Battery Charging

The battery charging procedure is controlled by the processor, thus maintaining its best possible preservation, as it extends its duration.

Battery Cut-off

The luminaire enters this mode when the mains power supply fails and battery has lost all its energy. During this operation the luminaire enters the idle state and battery consumption is negligible, in order to be

protected from deep discharge.

Manual Operational Test

This test can be done by pressing the test button. The light source and the emergency circuit of the device are monitored for 3 sec. The manual test can be conducted only if the mains power supply and the battery are connected. During this test period all indication LEDs are OFF.

Automatic Operational Test

This test includes all the operations of the manual test and is conducted automatically every 15 days. In order to be performed, the mains power supply and the battery should be connected.

Automatic Autonomy Test

The Automatic Autonomy Test measures the device's back up operation and emergency duration. This test is conducted automatically every 6 months. In order to be performed, the mains power supply and the battery should be connected and fully charged. If the battery is not fully charged, the test is postponed until the battery is completely charged. If during this test, the autonomy is less than nominal, the battery fault led turns on continuously and

the battery must be replaced.

Emergency Operation

The autonomy duration of battery during emergency mode is at least 90 or 180 minutes, depending on the model. During emergency mode, a light source test is also performed.

Addressable Communication

The luminaire has the ability to be connected to GR-6500 panel. In order to do so, the luminaire's address has to be unique in the same bus. For more details see page 3 (installation instruction).

Resetting Errors

Push the Test button for more than 10 seconds, to delete all the indicated LED errors. Then the device enters regular operation mode.

Indication LED status (with connected mains power supply).

Charge (Green LED)

Blink: Battery is charging.

On: Good charge condition.

Off: No battery (No charging current or disconnected battery).

Fault (Red LED)

On : Faulty LED strip (must be replaced) or emergency circuit (must be checked by an authorized personnel).

Blink (With Charge LED ON): Autonomy or low battery problem (**the battery must be replaced**).

Off: LED strip and battery ok.

ATTENTION!!!

1. Operations for installation, maintenance or testing must be done by authorized personnel only.
2. The device must be connected to the mains power supply through a fuse dependent by the total amount of the line's power load.

3. In case of inactive use for a period greater than 2 months, disconnect the battery by pulling out the battery's connector.

4. **It is not allowed to discard batteries in to common trash bins, they must be discarded only in battery recycling points. Do not incinerate.**



NOTE: LED= Light Emitting Diode

LABELING EXPLANATION:

X: Self contained

1: Maintained (*)

A: Including test device

F: Automatic test gear complying with IEC 61347-2-7 denoted EL-T

90: 1.5 hour duration

180: 3 hours duration

NOTE!! The installer should fill in, on the specification label, the letter **G** if the luminaire is used as a safety sign.



(*) Maintained operation: The luminaire lights its illumination source, when it is powered by the mains power supply or not.

Non Maintained operation: The luminaire lights its illumination source, only in power supply's failure.

Battery replacement.

It can be done only by a competent person and after the mains interruption.

1. Dismantle the device (step 1 of the installation instructions).
2. Disconnect the connector and remove the old battery.
3. Connect the new battery with the same type (step 4 of the installation instructions) and place it in the position of the old one.
4. Follow the step 6 of the installation procedure and power the device.

LED MODULE CHARACTERISTICS

	GR-2100/ST/M/ADR	GR-2110/ST/M/ADR
Manufacturer	Olympia Electronics S.A	
Model Number	3105165	
Voltage Range	8.7-10.8VDC	
Nominal Power	780mW	
Connections	Non reversible connection between main pcb and led module	
Temperature (tc)	45 °C max. across the board	

INSTALLATION INSTRUCTIONS

Figure 1

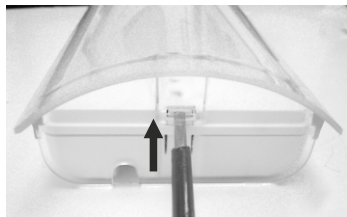

Figure 2

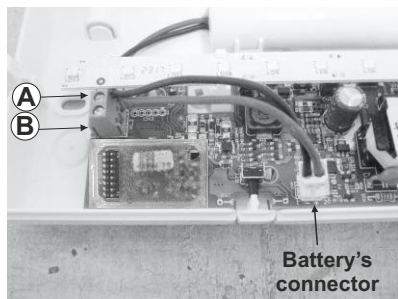
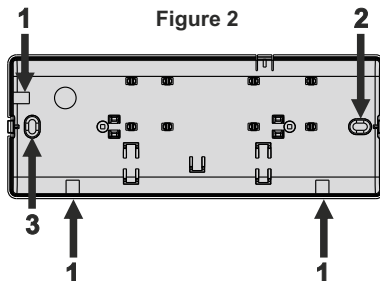

Figure 3

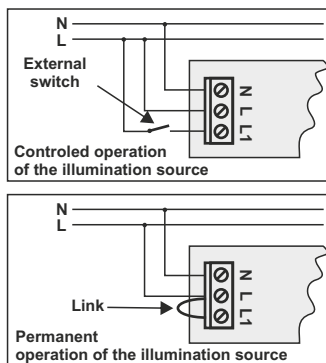

Figure 4

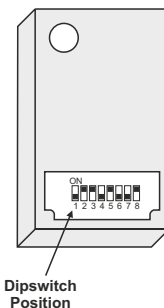

Figure 5











1. To instal the device you have to dismantle carefully the device with a flat screwdriver as shown on figure 1.
2. Pass the mains cables through one of points 1 on figure 2. The luminaire must be connected to a permanent electrical installation to ensure the immobilization of the cable.
3. Mount the base plastic on the wall by using the included mounting accessories in points 2 and 3 on figure 2.
4. Connect the mains cables to the respective detachable terminal block. **N for neutral, L for live wire and L1 for the maintained operation.** The L1 wire can be connected to an external switch to control the maintained or non maintained operation of the luminaire. For permanent maintained operation use two wires to power the luminaire, N for neutral and L for live wire, and link the L and L1.
5. Follow step 2 in order to pass the 2 signal cables and connect them on the A, B terminals minding the correct polarity. These cables are used to connect the luminaire to GR-6500 panel.
6. Set the luminaire's address through the DIP switch. See table at pages 4 to 6.
7. Connect the battery's cable with the appropriate terminal (figure 3).
8. Refit with care the removed plastic parts and power on the luminaire.

NOTE!!

After finishing the installation you must power the luminaire at least for 24 hours for battery charging to perform the nominal autonomy.

Address	Dipswitch setting	Address	Dipswitch setting	Address	Dipswitch setting	Address	Dipswitch setting
1		31		61		91	
2		32		62		92	
3		33		63		93	
4		34		64		94	
5		35		65		95	
6		36		66		96	
7		37		67		97	
8		38		68		98	
9		39		69		99	
10		40		70		100	
11		41		71		101	
12		42		72		102	
13		43		73		103	
14		44		74		104	
15		45		75		105	
16		46		76		106	
17		47		77		107	
18		48		78		108	
19		49		79		109	
20		50		80		110	
21		51		81		111	
22		52		82		112	
23		53		83		113	
24		54		84		114	
25		55		85		115	
26		56		86		116	
27		57		87		117	
28		58		88		118	
29		59		89		119	
30		60		90		120	

Address	Dipswitch setting	Address	Dipswitch setting	Address	Dipswitch setting	Address	Dipswitch setting
121		151		181		211	
122		152		182		212	
123		153		183		213	
124		154		184		214	
125		155		185		215	
126		156		186		216	
127		157		187		217	
128		158		188		218	
129		159		189		219	
130		160		190		220	
131		161		191		221	
132		162		192		222	
133		163		193		223	
134		164		194		224	
135		165		195		225	
136		166		196		226	
137		167		197		227	
138		168		198		228	
139		169		199		229	
140		170		200		230	
141		171		201		231	
142		172		202		232	
143		173		203		233	
144		174		204		234	
145		175		205		235	
146		176		206		236	
147		177		207		237	
148		178		208		238	
149		179		209		239	
150		180		210		240	

Address	Dipswitch setting
241	ON 
242	ON 
243	ON 
244	ON 
245	ON 
246	ON 
247	ON 
248	ON 
249	ON 
250	ON 



The light source contained in this luminaire shall only be replaced by the manufacturer, or his agent, or a similar qualified person.

NOTE! *The light source is non-user replaceable.*

WARRANTY

Olympia Electronics guarantees the quality, condition and operation of the goods. The period of warranty is specified in the official catalogue of Olympia Electronics and also in the technical leaflet, which accompanies each product. This warranty ceases to exist if the buyer does not follow the technical instructions included in official documents given by Olympia Electronics or if the buyer modifies the goods provided or has any repairs or re-setting done by a third party, unless Olympia Electronics has fully agreed to them in writing. Products that have been damaged can be returned to the premises of our company for repair or replacement, as long as the warranty period is valid.

Olympia Electronics reserves the right to repair or to replace the returned goods and to or not charge the buyer depending on the reason of defection. Olympia Electronics reserves the right to charge or not the buyer the transportation cost.

HEAD OFFICE

72nd km. O.N.R. Thessaloniki-Katerini
P.C. 60300 P.O. Box 06 Eginio Pierias Greece

www.olympia-electronics.gr

info@olympia-electronics.gr