

Package Contents

- 1 Luminaire
- 1 Mounting accessories
- 1 Rubber sealing ring
- 1 Manual

General

Manual Operational Test

The operational test is initiated by placing the magnetic test card A-1900 on the "TEST" indication and removing it immediately. This test checks the light source and the emergency circuit of the device. The manual operational test can only be conducted if the mains power supply and the battery are connected. During the test, the CHARGE LED blinks rapidly. The battery must have sufficient charge. This test lasts for 3 seconds.

Manual Autonomy Test

The manual autonomy test is initiated by placing the magnetic test card A-1900 on the "TEST" indication and holding it for 5-10 seconds. This test can only be performed if the mains power supply is connected and the battery is fully charged. The luminaire enters emergency mode, and the CHARGE LED blinks rapidly. The test duration corresponds to the luminaire's specified autonomy time. If the autonomy is lower than the nominal value at the end of the test, the FAULT LED will illuminate, indicating that the battery needs to be replaced. If the test result is satisfactory, the luminaire enters charging mode, and the CHARGE LED blinks rapidly until the battery is fully charged.

Automatic Operational Test

This test includes all operations of the Manual Operational Test and is conducted automatically every 15 days, lasting 3 seconds.

Automatic Autonomy Test

The Automatic Autonomy Test is conducted annually to measure the device's backup operation and emergency duration. This test includes all the functions of the Manual Autonomy Test.

ATTENTION!

1. Installation, maintenance, or testing operations must be carried out by authorized personnel only.
2. Always use a round mains cable with a diameter of 5-10mm (H05RN-F type 2x1mm² or any other type with at least equivalent mechanical and electrical properties). ATTENTION! The cable must not be deformed in any way to ensure the IP rating.
3. The device must be connected to the mains power supply through a circuit breaker appropriate for the total power load of the line.
4. In case of battery replacement, the battery must be of the same type and replaced by the manufacturer or a qualified person.
5. If the luminaire is not in use for more than 2 months, disconnect the battery by unplugging the battery connector.
6. If the luminaire no longer meets the rated autonomy after a full recharge period, the battery must be replaced.
7. To prevent multiple luminaires from performing their autonomy tests simultaneously, ensure at least 1.5 minutes between connecting the battery packs.
8. Batteries must not be disposed of in regular waste bins. They should be disposed of only at designated battery recycling points. Do not incinerate.

Indications LED Status

GREEN (charge)	RED (Fault)	Description
●	○	Normal
●	○	Charging (autonomy test not possible while charging)
○	○	Mains off (battery not connected or charger fault)
●	○	Autonomy Test (Luminaire's autonomy duration)
∅	●	Battery Fault
●	○	Operational Test (Duration: 3s)
∅	●	Light Source Fault
∅	●	Battery Fault & Light Source Fault
Note:		● Permanently ON ∅ Fast Blink ● Slow Blink ○ Off ∅ Non relevant

Installation

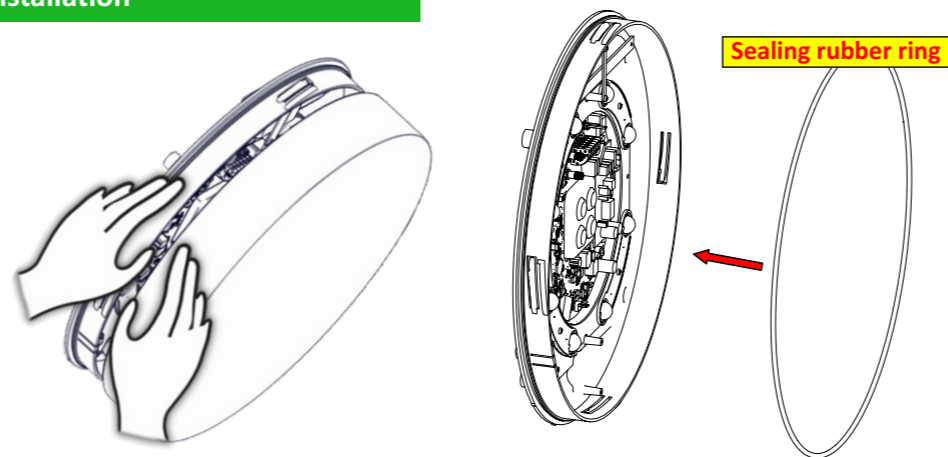

1. To disassemble the luminaire, pull the diffuser carefully and detach it from the base.
2. To ensure an IP65 rating, install the included sealing rubber ring onto the luminaire's base.

1 Functions

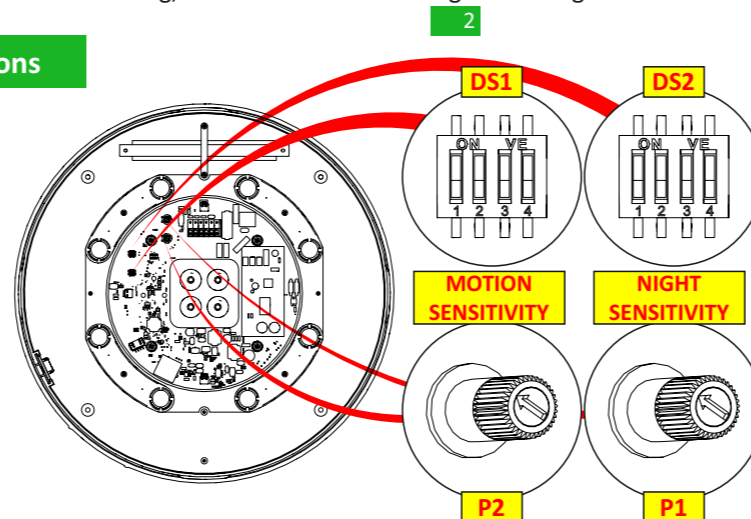

DS2 FUNCTIONS

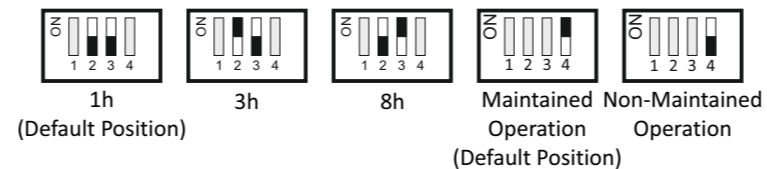

The user can select one of the three available minimum autonomy durations: 1 hour, 3 hours, or 8 hours. Selection is made using Switches 2 and 3 of DS2.

The package includes two additional labels: one for a 3-hour duration (180) and one for an 8-hour duration (480).

Depending on the selected duration, the installer must replace the default 1-hour (60) label with the appropriate label. Ensure that the label is correctly oriented.

The luminaire's maintained or non-maintained operation is controlled via Switch 4 of DS2.

ATTENTION! Selection must be performed while the luminaire is disconnected from both the AC power supply and the battery.

DS1 FUNCTIONS (RADAR SENSOR)

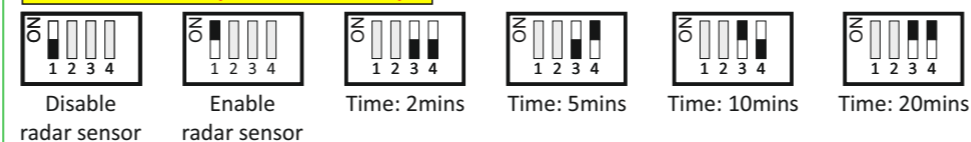

Radar Sensor Configuration

The user can enable or disable the radar sensor using Switch 1 of DS1.

- To enable the radar sensor, set Switch 1 to the ON position.
- To disable the radar sensor, set Switch 1 to the OFF position.

The user can also adjust the motion sensitivity by using the shaft knob located at position P2.

Motion Detection Time Settings

The duration for which the luminaire remains illuminated after detecting motion is configured using Switches 3 and 4 of DS1:

- 2 minutes → Switch 3: OFF, Switch 4: OFF
- 5 minutes → Switch 3: OFF, Switch 4: ON
- 10 minutes → Switch 3: ON, Switch 4: OFF
- 20 minutes → Switch 3: ON, Switch 4: ON

DS1 FUNCTIONS (NIGHT MODE)

To enable the Night Mode function, set Switch 2 of DS1 to the ON position. When Night Mode is enabled, the luminaire detects motion only at night. If Switch 2 is in the OFF position, the luminaire detects motion both day and night.

The user can also adjust the night mode sensitivity by using the shaft knob located at position P1.

ATTENTION! Selection for **Radar mode and Night mode** must be performed while the luminaire is disconnected from both the AC power supply and the battery.

Note: The motion sensor functions only when the luminaire is connected to AC power and operates in maintained mode, either through the DS2 dip switch or an external switch (L1).

3

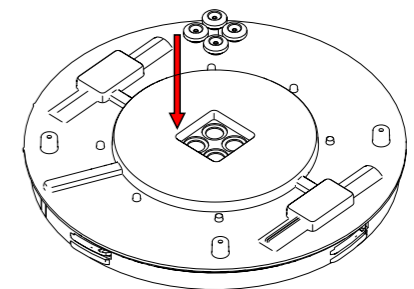

Install the four included rubber gaskets, ensuring they are not deformed.

4

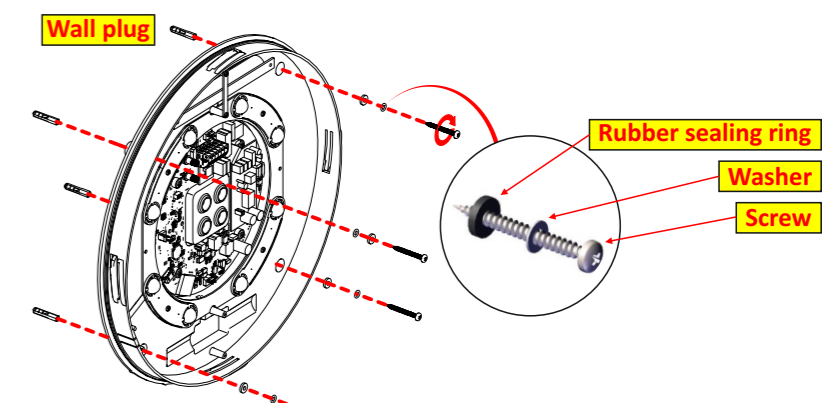

Mount the luminaire's base to the wall or ceiling using the included mounting accessories. Ensure that the indicator LEDs are visible and not facing a wall.

5

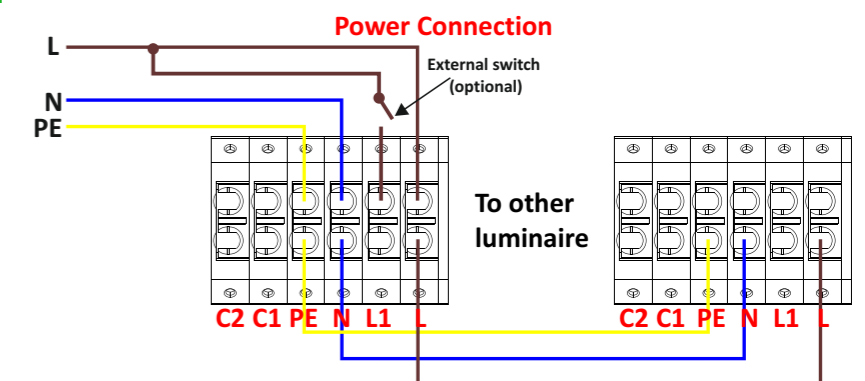

Use a small screwdriver to make a hole in the center of a rubber gasket. Pass the round cable through the gasket. Connect the mains cable to the corresponding terminal block: L for the live wire, N for the neutral wire, and PE for the ground wire. PE is for termination purposes only. L1 (optional) is used for the controlled operation of the luminaire. The power supply cable cross-section should be 0.8–2.5 mm².

6

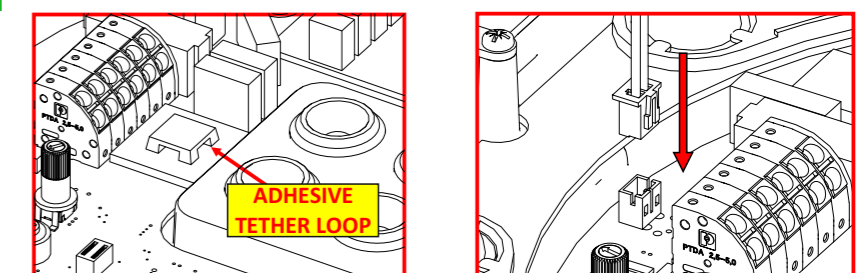

7. Install the included adhesive tether loop and use the included tie wrap to securely fasten the power cable, ensuring it is properly anchored.

8. Connect the battery's connector to the corresponding connector on the PCB.

7

8

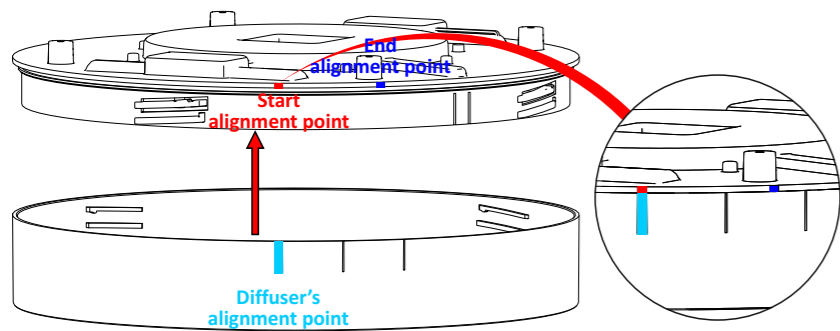

Place the diffuser back onto its base. Pay attention to its orientation—the alignment point of the diffuser must be positioned correctly with the starting alignment point of the base.

9

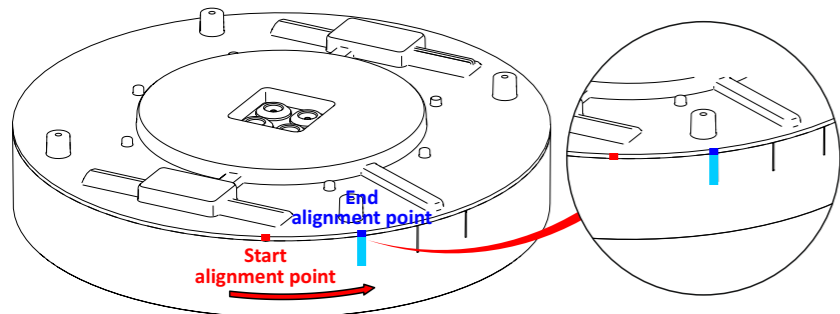

Rotate the luminaire's diffuser until it locks at the end alignment point of the base. You should hear a clicking sound. Ensure there are no gaps between the diffuser and the base to maintain the IP65 rating.

10

Note: After completing the installation, you must power the luminaire for at least 24 hours to fully charge the battery. The rated autonomy duration will be achieved after this period.

Battery Replacement

It can be done only by a competent person and after the mains interruption.

1. Disassembly the luminaire.
2. Disconnect the battery and install a new one of the same type and characteristics.
3. Re-assembly the luminaire.

Dimensional drawing 360 Ø x 74 (mm)

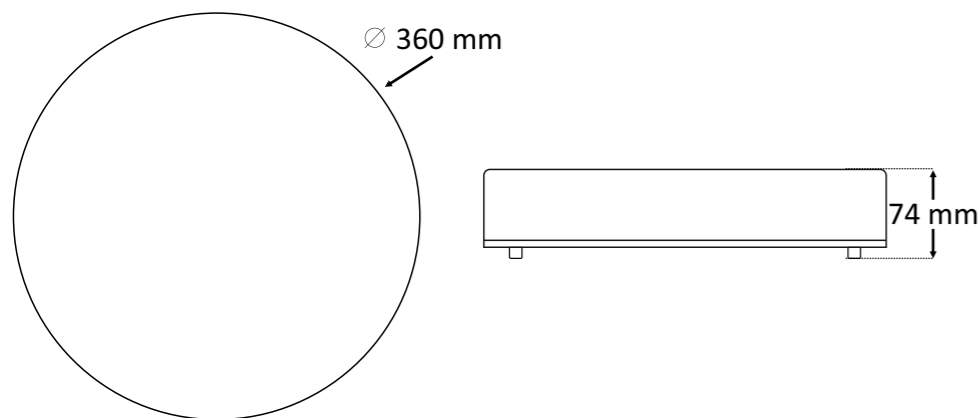

NOTE: LED= Light Emitting Diode

LABELING EXPLANATION:

- X: Self contained
- 1: Maintained/Non maintained operation (*)
- A: Including test device
- E: With non-replacable lamp(s) and/or battery
- F: Automatic test gear complying with IEC 61347-2-7 denoted EL-T
- 60: 1 hour duration
- 180: 3 hours duration
- 480: 8 hours duration

X 1 A E F 6 0

(*) **Maintained operation:** The luminaire lights its illumination source, when it is powered by the mains power supply or not.

Non Maintained operation: The luminaire lights its illumination source, only in power supply's failure.

ATTENTION

The light source of this luminaire is not user replaceable. When the light source reaches its end of life the whole luminaire shall be replaced.

4

92340001_09_001

Technical Characteristics

KLS PRO-400/LF/WP	
OPERATION VOLTAGE	220 - 240V AC / 50-60Hz
MAXIMUM POWER CONSUMPTION	18W / 19.3VA
SUPPLY CURRENT	84mA
U-OUT	11.2V
Prated	11.2W
Irated	1A
MAX. OPERATION CIRCUIT VOLTAGE	13V
WIRE CROSS SECTION	0.8 - 2.5mm ²
MINIMUM POWER FACTOR	0.25
INSULATION BETWEEN SUPPLY & CONTROL TERMINALS	Basic Insulation
INSULATION BETWEEN SUPPLY & BATTERY CIRCUIT	Basic Insulation
BATTERY (LiFePO ₄)	2 x 6.4V / 2Ah
BATTERY PROTECTION	Deep discharge and overcharge protection The control gear will recharge the battery normally after the test of 22.3
MIN. MAX. DISCHARGE VOLTAGE	5.4V - 7.1V
MIN. MAX. DISCHARGE CURRENT	2200 - 410mA
MIN. MAX. CHARGE CURRENT	150 - 250mA
TRICKLE CHARGE VOLTAGE/CURRENT	7.1V - 0mA
MAX CHARGER VOLTAGE	7.5V
INDICATIONS/CONTROLS	LED Fault, LED Charge / Magnetic Switch
CHARGE TIME	23 hours
MINIMUM DURATION	1 - 3 - 8 hours
LIGHT SOURCE	8 White Power LED
LIGHT SOURCE LUMINUS FLUX (MAINS)	2050lm
LIGHT SOURCE LUMINUS FLUX (EMERGENCY)	1h: 2000lm 3h: 850lm 8h: 370lm
DEGREES OF COVER PROTECTION	IP65
PRODUCED IN ACCORDANCE WITH	EN 60598-1, EN 60598-2-22, EN 55015, EN 61547, EN 61000-3-2, EN 61000-3-3
OPERATION TEMPERATURE RANGE	5 - 40°C
CONTROL GEAR MAX. TEMPERATURE: tc	72°C at U2
RELATIVE HUMIDITY	Up to 95%
CONSTRUCTION MATERIAL	ABS/PC, PC
MATERIAL COLOR	White
EXTERNAL DIMENSIONS (L x W x H)	360 Ø x 74 mm
WEIGHT	1500gr
GUARANTEE	10 years
CONTROL GEAR WITH AUTOMATIC TEST FUNCTION	EL-T
LED Characteristics*	
MANUFACTURER	Olympia Electronics S.A.
MODEL NUMBER	1302243
VOLTAGE RANGE	11.2V - 12.5V
NOMINAL POWER	11.2W
CONNECTIONS	Cable connection
TEMPERATURE (tc)	60°C max. across the board

Warranty



72nd km. O.N.R. Thessaloniki-Katerini
P.C. 60300 P.O. Box 06 Eginio Pierias Greece
www.olympia-electronics.com
info@olympia-electronics.com

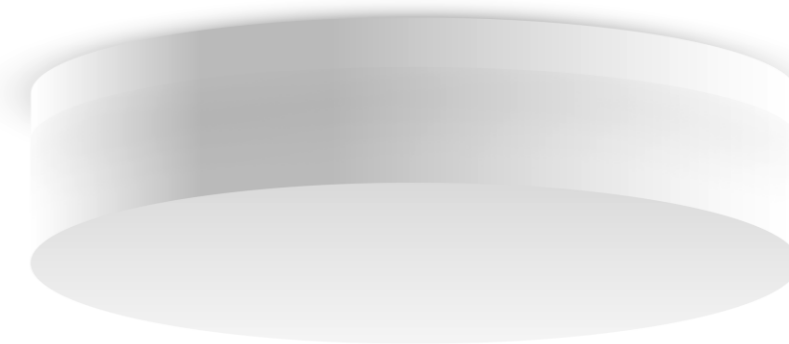

KLS PRO-400/LF/WP

SELF TESTING MAINTAINED/NON MAINTAINED
EMERGENCY LUMINAIRE WITH MOTION SENSOR



Thank you for your trust in our products
Olympia Electronics - European manufacturer

5

92340001_09_001