



WATERPROOF SELF TESTING NON-MAINTAINED EMERGENCY CEILING MOUNTED LUMINAIRES



TECHNICAL CHARACTERISTICS *(for LED MODULE specifications see page 6)*

	GR-490/WP	GR-491/WP	GR-492/WP	GR-493/WP
OPERATION VOLTAGE	220-240V AC / 50-60Hz			
MAXIMUM POWER CONSUMPTION	3.9W / 4.4VA			
BATTERY (Ni-Mh)	4.8V/1.2 Ah			
BATTERY PROTECTION	Deep discharge and overcharge protection			
INDICATIONS	LED Charge , Lamp Fault LED, Battery Fault LED / Magnetic Test Contact			
CHARGE TIME	24 hours			
MINIMUM DURATION	1.5 hour			3 hour
LIGHT SOURCE	1 white power LED			
EMERGENCY ILLUMINATION	280lm			140lm
DEGREES OF COVER PROTECTION	IP65			
PRODUCED IN ACCORDANCE WITH	EN 60598-1, EN 60598-2-22, EN 55015, EN 61547, EN 61000-3-2, EN 61000-3-3			
OPERATION TEMPERATURE RANGE	5 to 40 °C			
RELATIVE HUMIDITY	Up to 95%			
CONSTRUCTION MATERIAL	ABS/PC, PC			
EXTERNAL DIMENSIONS	158 x 158 x 60,4mm (without decorative bezel) - 195 x 195 x 60,4 (with decorative bezel)			
WEIGHT	576gr.			
GUARANTEE	3 years (1 year for the battery)			

Thank you for your trust in our products Olympia Electronics - European manufacturer

GENERAL

These devices are used indoors (ta 40°C) in places where emergency luminaires are needed. The luminaires GR-490/WP and GR-492/WP are suitable for corridors lighting and the GR-491/WP and GR-493/WP for open area lighting. Each device must be permanently connected to mains power supply. In normal operation the battery is charging. In case of a mains power supply failure, the device enters emergency mode and the illumination LED turns on. When the mains power supply is restored the device turns to normal operation.

INSTALLATION

To install the luminaire follow the installation instructions on page 3.

Battery Charging

The battery charging is completely controlled by microprocessor and is protected from complete discharge and overcharge.

Battery Cut-off

The luminaire enters in this mode when the mains power supply fails and battery has lost its energy. During this mode the luminaire enters the idle state and battery consumption

is negligible, in order to be protected from deep discharge.

Manual Test

This test can be done by using the A-1900 card as described on page 6. The light source and the emergency circuit of the device are tested. The manual test can be conducted only if the mains power supply and the battery are connected. During this test period the LAMP TEST LED will blink.

Manual Autonomy Test

A duration test can be conducted by holding the A-1900 card steadily for 5 to 10 seconds. In order to be performed, the mains power supply and the battery should be connected. The luminaire enters emergency mode, the charge LED is turned OFF and the Battery Fault led starts to blink. The test is performed until the battery is fully discharged. If at the end of the test the autonomy is low then the Battery Fault LED will be ON. If the result of the test is good then the luminaire enters charging mode and the Charge led starts to blink until the batteries are fully charged.

Automatic Operational Test

This test includes all the operations that are provided in manual test and is conducted automatically every 15 days. In order to be performed, the mains power supply and the battery should be connected.

Automatic Autonomy Test

The Automatic Autonomy Test tests the device's back up operation and emergency duration. This test is conducted automatically every 6 months. In order to be performed, the mains power supply should be connected and the battery must be fully charged. If the battery is not fully charged, the test is postponed until the battery is completely charged. If during this test, the autonomy is less than nominal then the battery fault LED will permanently be on and the battery must be replaced.

Back Up Operation

The autonomy duration of battery during emergency mode must be at least as the one stated in the list of the technical characteristics. During emergency mode, a light source test is also performed.

Resetting Errors

Hold the A-1900 card in TEST position for 10 to 15 seconds in order to delete all LED indicated errors. Then the device enters regular operation mode.

ATTENTION!!!

1. Operations for installation, maintenance or testing must be done by authorized personnel only.
2. The device must be connected to the mains power supply through a fuse that is dependent on the total line's power load.
3. In case of battery or lamp replacement, these must be replaced by parts with same type, by the manufacturer or by a competent person.
4. In case of inactive use for a period greater than 2 months, disconnect the battery by pulling out the battery's connector.
5. It is not allowed to discard batteries in



to common trash bins, they must be discarded only in battery recycling points. Do not incinerate.

Indication LED status (mains on)

Charge

On: Fully charged.

Off: No battery (No charging current or disconnected battery).

Blink: Charging.

Lamp Fault

On: Faulty LED.

Off: LED OK.

Blink: Operational Test.

Battery Fault

Off: Battery OK.

ON (With Charge LED ON): Autonomy or low battery problem (**the battery must be replaced**).

Blink (With Charge LED Off): Autonomy test is performed.

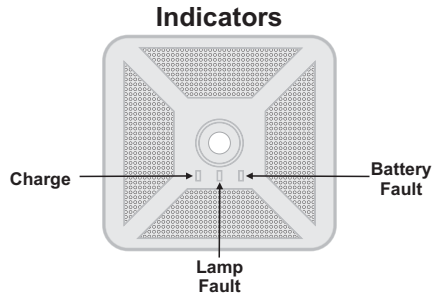

INSTALLATION INSTRUCTIONS

①

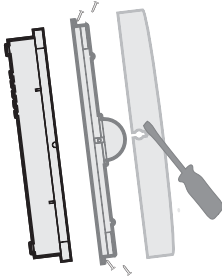

②

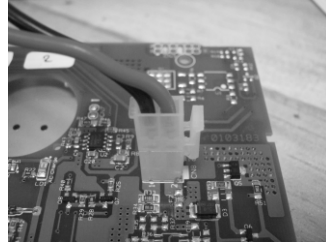

③

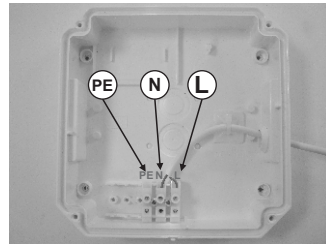
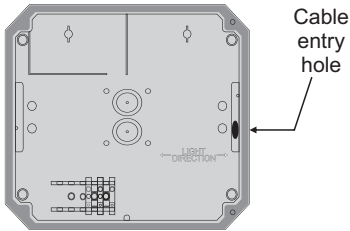

Initial installation

1. Detach the front cover by applying pressure using a flat blade screw driver. Next, unfasten the four retaining screws without removing them and remove the diffuser.
2. Install the battery connector to its corresponding connector on the main pcb.
3. Install the cable grommet in the open hole of the plastic base and open a hole in the center of the grommet using a small screw driver. Pass the power cable through the hole in the grommet. (If required, open another cutout cable entry hole and install the second supplied cable grommet). Connect the cables as shown in the photograph. Use the supplied self adhesive pad and cable tie to anchor the cable.
4. Reinstall the diffuser and re-tighten the 4 screws in a diagonally manner with a torque of $0,9 \text{ N}^*\text{m}$.

NOTE!! After finishing the installation you must power the luminaire for at least 24 hours in order to completely charge the battery. The rated autonomy duration can be achieved after that time.

GR-490/WP, GR-492/WP

Corridor
lighting

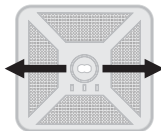

ATTENTION!!!

During installation follow this light direction.

GR-491/WP, GR-493/WP

Open
area
lighting



MOUNTING IN SUSPENDED CEILING

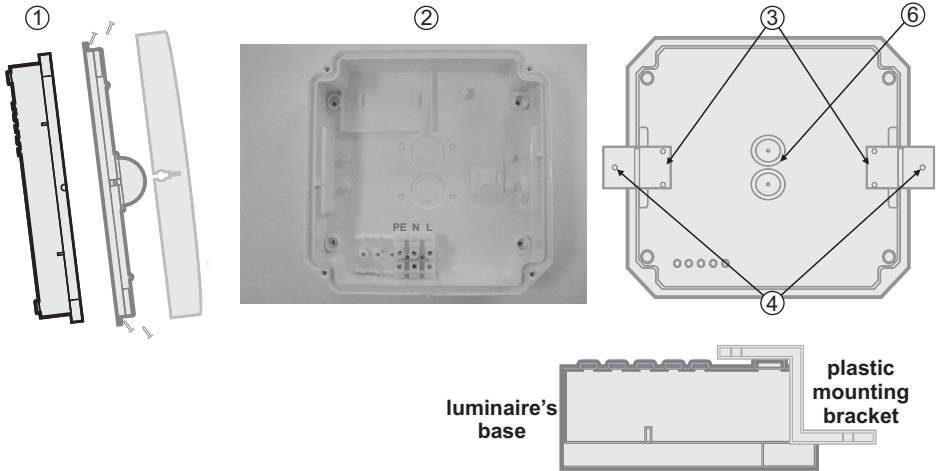

luminaire's
base

plastic
mounting
bracket

***Required opening
14.5x14.5cm***

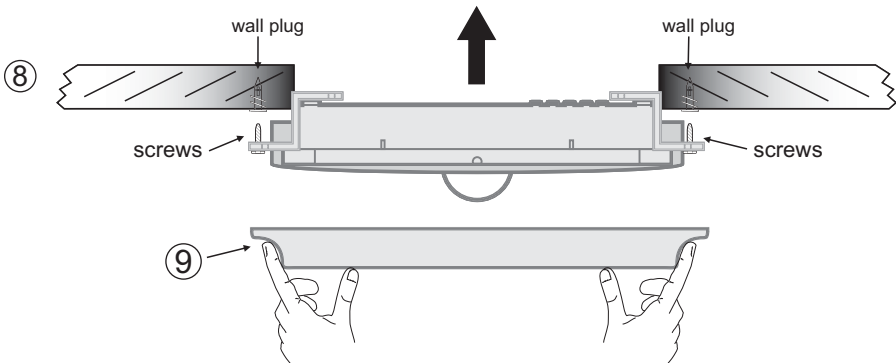

1. Detach the front cover by applying pressure using a flat blade screw driver. Next, unfasten the four retaining screws (figure 1) without removing them and remove the diffuser.
2. Install the supplied cable grommet from the inside of the plastic base (figure 2).
3. Install the two plastic brackets with the four screws (figure 3).
4. Mark the positions of the mounting holes on the brackets.
5. Install the two supplied plaster board plugs by screwing them on the plaster board ceiling.
6. Open a cable entry cutout hole on the plastic base and follow step 3 in the "initial installation" section.
7. Re-install the front cover that was removed in step 1.
8. Use the supplied screws to fasten the luminaire to the plaster board plugs (figure 8) that were previously installed on the plaster board ceiling.
9. Finally, install the supplied decorative bezel (figure 9). The notch on the bezel must be located on the left side of the luminaire (figure 10).

MOUNTING IN SUSPENDED CEILING

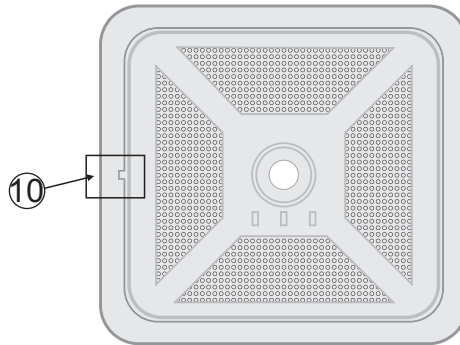

SURFACE MOUNTING

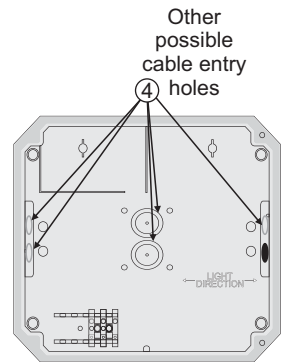
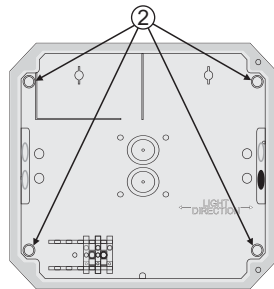
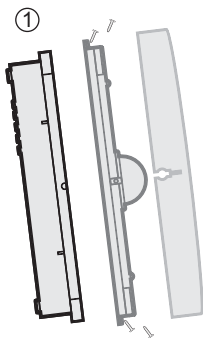

⑤

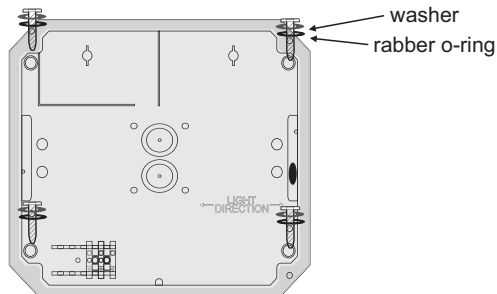

1. Detach the front cover by applying pressure using a flat blade screw driver. Next, unfasten the four retaining screws without removing them and remove the diffuser.
2. Use a drill with a 3,5mm bit to open the 4 mounting holes (figure 2) located in the plastic base..
3. Place the luminaire on the desired mounting location and mark and drill these 4 holes. Fit the supplied 4 plastic mounting plugs to these drilled holes on the mounting location.
4. If the cable entry hole is not suitable then use one of the supplied cables grommets to cover the holes and open another cable entry cut out hole (figure 3). Follow step 3 of the “ **initial installation procedure**”.
5. Mount the base to the desired location by using the supplied screws, washers and o-rings in each mounting hole (figure 5).
6. Re-install the cover that was removed in step 1.

LED MODULE CHARACTERISTICS

	GR-490/WP	GR-491/WP	GR-492/WP	GR-493/WP
Manufacturer	Olympia Electronics S.A.			
Model Number	0405183			
Voltage Range	3-3,1V DC		2,8-2,9V DC	
Nominal Power	2W		1W	
Connections	fixed connection between main pcb and led module			
Temperature (tc)	65 °C max. across the board			

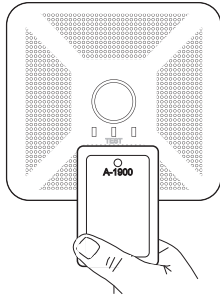

Test and Faults Reset operations with the A-1900 card (not included and available after request).

For lights test, you must place the card in front of the TEST indicator and remove it immediately.

For Autonomy Test, you must place the card in front of TEST and hold it for 5 to 10 seconds.

To reset errors you must place the card in front of TEST by holding it for 10 to 15 seconds and removing it.

NOTE: LED= Light Emitting Diode

LABELING EXPLANATION:X: Self contained

0: Non maintained (*)

A: Including test device

E: With non-replaceable lamp(s)

F: Automatic test gear complying with IEC 61347-2-7 denoted EL-T

90: 1.5 hour duration

180: 3 hours duration

X|0|A|E|F|1|8|0

(*) Non Maintained operation: The luminaire turns on illumination source, only in case of power supply failure.



CAUTION : Do not view directly with bare eyes

ATTENTION!!!



The light source of this luminaire is not replaceable when the light source reaches its end of life the whole luminaire shall be replaced.

Battery replacement

It can be done only by a competent person and after the mains interruption.

1. Detach the front cover by applying pressure using a flat blade screw driver. Next, unfasten the four retaining screws without removing them and remove the diffusor.
3. Disconnect the connector and remove the old battery.
4. Connect the new battery with the same type (step 2 of the installation instructions) and place it in the position of the old one.
5. Replace the removed parts and power the device.

WARRANTY

Olympia Electronics guarantees the quality, condition and operation of the goods. The period of warranty is specified in the official catalogue of Olympia Electronics and also in the technical leaflet, which accompanies each product. This warranty ceases to exist if the buyer does not follow the technical instructions included in official documents given by Olympia Electronics or if the buyer modifies the goods provided or has any repairs or re-setting done by a third party, unless Olympia Electronics has fully agreed to them in writing. Products that have been damaged can be returned to the premises of our company for repair or replacement, as long as the warranty period is valid.

Olympia Electronics reserves the right to repair or to replace the returned goods and to or not charge the buyer depending on the reason of defection. Olympia Electronics reserves the right to charge or not the buyer the transportation cost.

HEAD OFFICE

72nd km. O.N.R. Thessaloniki-Katerini
P.C. 60300 P.O. Box 06 Eginio Pierias Greece

www.olympia-electronics.gr
info@olympia-electronics.gr