

GR-7610/V2 i-OLEG Olympia Electronics LumiGate



TECHNICAL CHARACTERISTICS

| | |
|-----------------------------|--|
| OPERATION VOLTAGE | 220-240VAC / 50-60Hz |
| POWER CONSUMPTION | 23VA |
| BATTERY TYPE | SPA 6V/1.3Ah (Lead acid) |
| BATTERY PROTECTION | over-charge / deep-discharge |
| CPU | quad-core 1.8GHz |
| RAM / FLASH MEMORY | 2GB / 32GB |
| INDICATION LEDS | Power / Battery / Faults |
| BUTTONS | Power ON / Reset |
| CONNECTIVITY | 1x USB 2.0 port, 1x USB 3.0 port, 1x Ethernet port (RJ-45), 1x HDMI port, Wi-Fi 802.11 b/g/n |
| DISPLAY | 7" capacitive touch IPS display (1024x600) |
| DURATION | 1Hour |
| HOUSING MATERIALS | ABS/PC |
| COLOUR | White |
| IP RATING | IP20 |
| PRODUCED IN ACCORDANCE WITH | EN 62479:2010, EN 62311:2008, EN 62368-1:2014 +AC:2015, ETSI EN 301 489-1 V1.9.2, ETSI EN 301 489-17 V2.2.1, EN 55032:2013 +AC:2013, EN 55024:2010, ETSI EN 300 328 V2.1.1 |
| MOUNTING METHODS | Wall mounting / Desktop |
| AMBIENT TEMPERATURE RANGE | 5 to 40 °C |
| STORAGE TEMPERATURE RANGE | -40 to 70 °C |
| MAXIMUM RELATIVE HUMIDITY | Up to 95% |
| WEIGHT | 1002gr. |
| DIMENSIONS (L x W x H) | 220 x 66 x 145 mm |
| WARRANTY | 2 years (1 year for the battery) |

The **GR-7610/V2** is the control device of the Wireless Emergency Lighting. The Phos4.0 software is pre-installed in the **GR-7610/V2**.

Features:

- Status indication LEDs (Power, Battery, Fault)
- 1x Ethernet connection (RJ45)
- 2x USB connection
- 1x HDMI connection
- WiFi Connection (802.11 b/g/n)
- System buzzer (alert on system fault)
- 1 hour of emergency duration

Button functions - Bt1:

- Long press (>3s): Turn-on and turn-off the device.

Button function - Bt2:

- Reset the system.

Button function - Bt3:

- Long press (>5s) : Hardware reset.

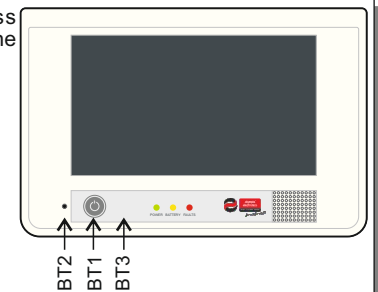

Recommended max devices: 400 (Gateway-Luminaires-Extenders-IO Units)

Gateways: 10

Luminaires - Extenders - IO Unit: 200 per gateway

Please follow the recommendation on maximum devices per tablet.

LED indications:

POWER (Green) : ON when the system is running and mains power is connected.
Blinking when the system is running and mains power or battery is disconnected [1 time/s].
Double blinking when the system is offline and battery is charging [2 times/s].
Triple blinking when the system is offline and mains power is connected [3 times/2s].
OFF when the system is offline and mains power is disconnected.

BATTERY (Yellow): ON when the battery is connected.
Blinking when the battery is depleted [1 time/s].
OFF when the battery is disconnected / system offline.

FAULT (Red) : ON when there is a current fault on the system.
Blinking when there is a new event [1 time/s].
OFF when no new event or fault are present.

Buzzer:

- Normal tone - fault notification (3Beeps/sec).
- Fast tone - battery is depleted / cut-off pending (5Beeps/s).

Default settings:

- Phos4.0 Software / Administrator menu password: 1000

Schematic 1: Wall mounting bracket

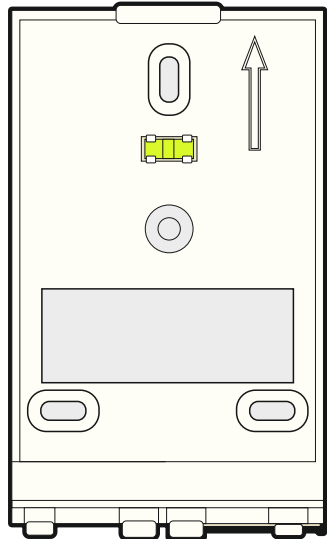

Schematic 2: Side connections

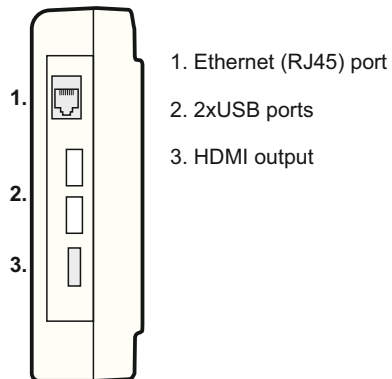

Installation:

- 1. Wall installation:** Mount the detachable bracket on a vertical wall surface (drill according to the mounting holes a, b, c). Use the spirit level to align horizontally. Put the device in the detachable bracket and tighten the screw on the bottom to secure it in place (d). Connect the mains power cable on the socket (e).
- 2. Table installation:** Screw the included metal stand on the back of the detachable bracket. Put the device in the detachable bracket and tighten the screw on the bottom to secure it in place (d). Connect the mains power cable on the socket (e).

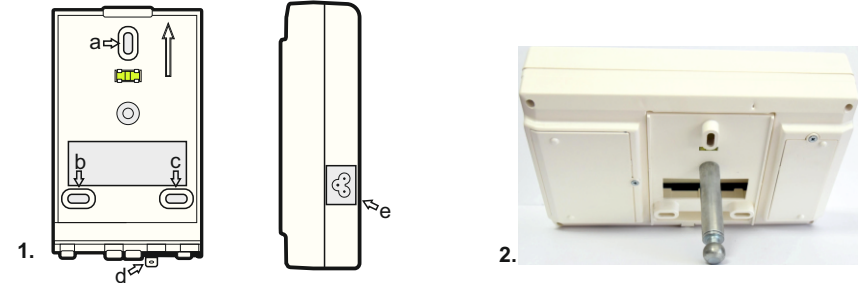

Battery replacement:

Deactivate the system, unscrew the battery cover, disconnect the battery and replace it. Fasten the battery cover again and reactivate the system.

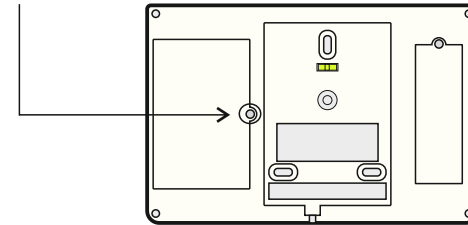

Do not throw batteries in common trash bins. Dispose of properly only in battery recycling points. Do not heat or incinerate! Do not short-circuit! Do not squeeze or shock! Do not disassemble! Replace with the same battery type only.

Warranty

Olympia Electronics guarantees the quality, condition and operation of the goods. The period of warranty is specified in the official catalogue of Olympia Electronics and also in the technical leaflet, which accompanies each product. This warranty ceases to exist if the buyer does not follow the technical instructions included in official documents given by Olympia Electronics or if the buyer modifies the goods provided or has any repairs or re-setting done by a third party, unless Olympia Electronics has fully agreed to them in writing. Products that have been damaged can be returned to the premises of our company for repair or replacement, as long as the warranty period is valid.

Olympia Electronics reserves the right to repair or to replace the returned goods and to or not charge the buyer depending on the reason of deflection. Olympia Electronics reserves the right to charge or not the buyer the transportation cost.

HEAD OFFICE

72nd km. O.N.R. Thessaloniki-Katerini
P.C. 60300 P.O. Box 06 Eginio Pierias Greece
www.olympia-electronics.com
info@olympia-electronics.gr