

## Package Contents

- 1 Luminaire
- 1 Lens Accessories
- 1 Set of Mounting Springs
- 1 Manual
- 2 Labels for 3 & 8 hours duration

## General

These devices are used indoors (ta 40°C) in places where emergency light is needed. Each device must be permanently connected to mains power supply. In normal operation the battery is charging. In case of a mains power supply failure, the device enters emergency mode and the illumination LED turns on. When the mains power supply is restored the device turns to normal operation.

### Automatic Operational Test

This test is conducted automatically every 15 days and lasts 3 seconds. The light source and the emergency circuit of the device are tested. The test can be conducted only if the mains power supply and the battery are connected. During this test period the light source will light up and the green LED will flash quickly. The battery must have adequate charge.

### Automatic Autonomy Test

The Automatic Autonomy Test is conducted every 6 months and measures the device's back up operation and emergency duration. In order to be performed, the mains power supply should be connected and the battery should be fully charged. During this test period the light source will light up and the green LED will flash quickly. This test lasts for the stated duration. In case the test shows a battery fault, then the battery needs to be replaced. After the replacement, the luminaire will charge the

battery. When the charge is finished, the luminaire will perform an automatic autonomy test which lasts for the stated duration. If the battery is in good condition then the LED indicator will turn off.

### ATTENTION!!!

1. Operations for installation, maintenance or testing must be done by authorized personnel only.
2. Always use in any case round mains cable, with a diameter of 5-10mm (H05RN-F type 2x1mm<sup>2</sup> or any other type, at least equal to it's mechanical and electrical properties). ATTENTION!! The cable must not be deformed in any way (This requirement is important to ensure the IP rating).
3. The device must be connected to the mains power supply through a circuit breaker that is depends on the total line's power load.
4. In case of battery replacement, it must be replaced by the same type, by the manufacturer or a competent person.
5. In case of inactive use for a period greater than 2 months, disconnect the battery by pulling out the battery's connector.

6. **It is not allowed to discard batteries into common trash bins, they must be discarded only in battery recycling points. Do not incinerate.**

## Indications LED Status

GREEN (charge)	RED (Batt./Lamp Fault)	Description
●	●	Normal
●	○	Charging (battery test not possible while charging)
○	○	Mains off (battery not connected or charger fault)
●	○	Battery Test (Duration: 1h, 3h, 8h)
●	●	Battery Fault
●	○	Light Source Test (Duration: 3s)
●	●	Light Source Fault
●	●	Battery Fault & Light Source Fault

### Note:

●	Permanently ON
●	Fast Blink
●	Slow Blink
○	Off

## Indications

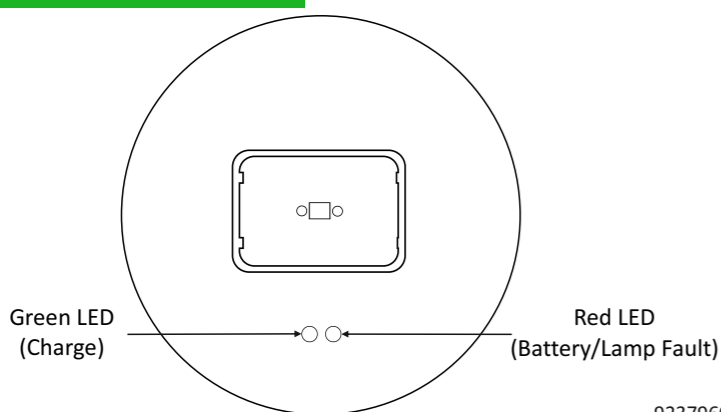

## Dimensions

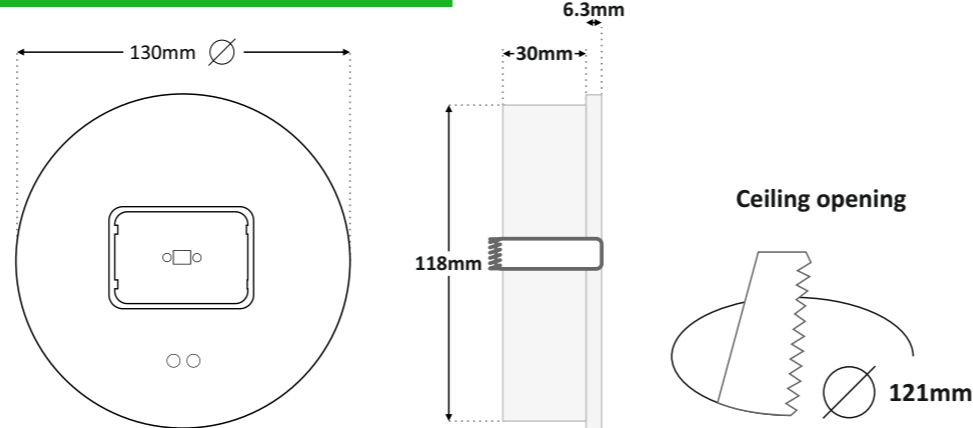

## Lens Installation

### Anti-Panic

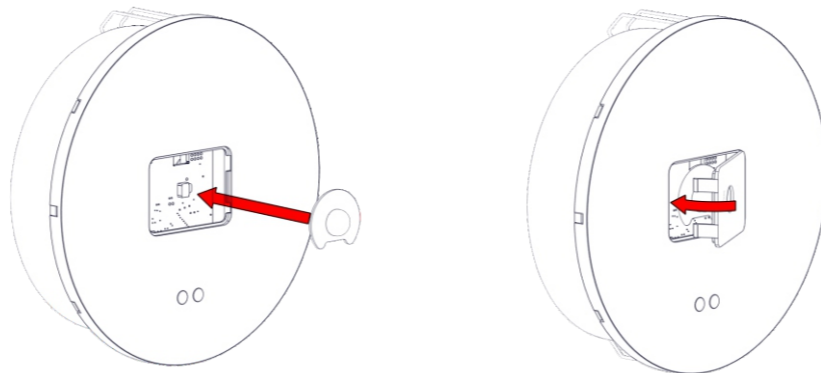

### Escape Route

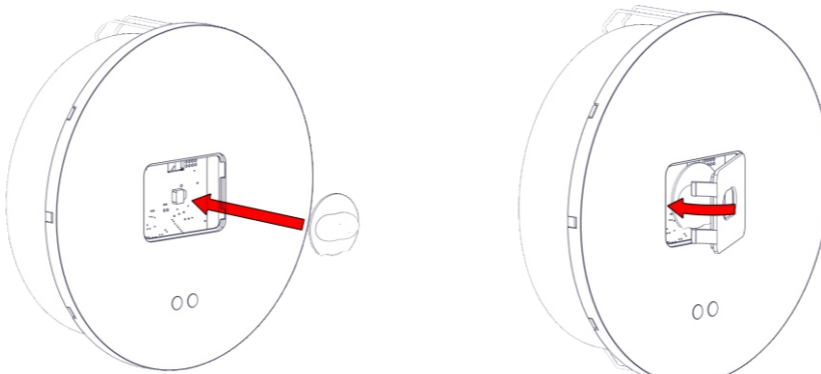

In order to place the proper lens (Anti - Panic or Escape Route), first be sure that the luminaire is not connected in the mains power supply and the battery is disconnected. Place the proper lens and retaining cover on the luminaire. **Be careful not touch the LED with your hand.**

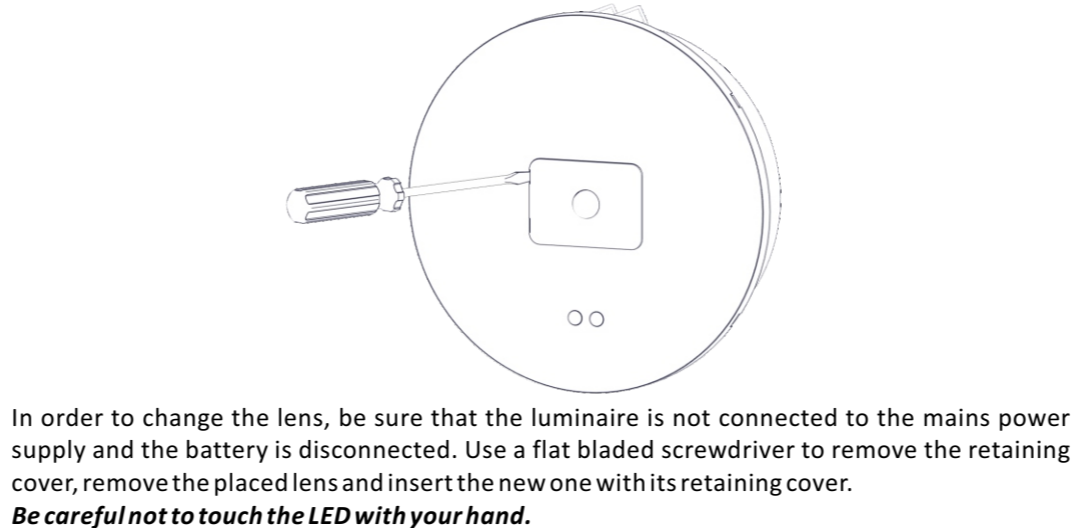

## Installation Instructions

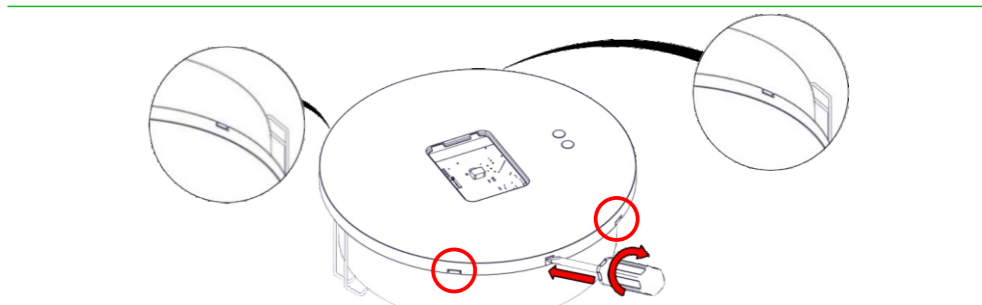
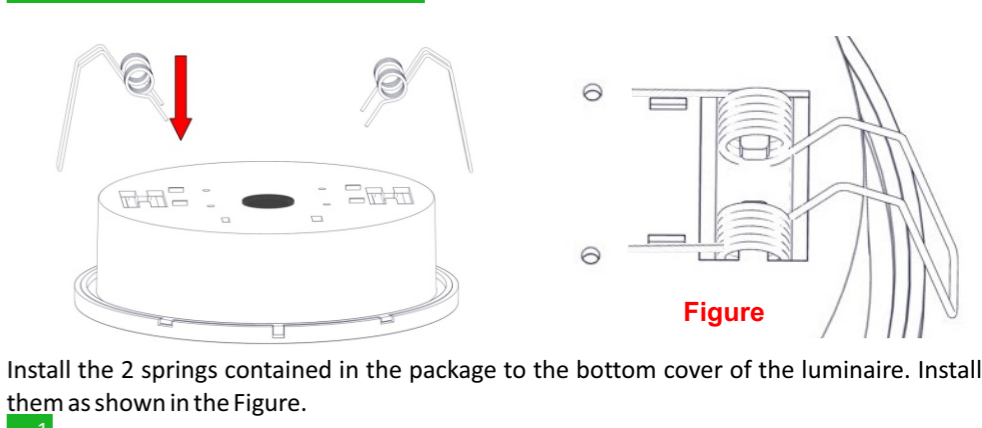

Place a flat blade screwdriver on the 5 marked positions and swift it, pull up gently the bottom cover and remove it.

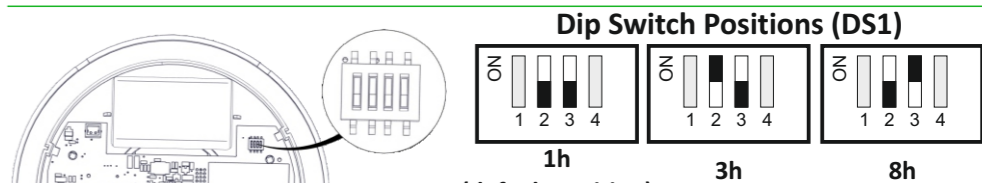

The user can select one of the 3 available minimum autonomy durations: 1 hour, 3 hours and 8 hours. The selection must be done while the luminaire is disconnected from AC and battery supplies. The selection is achieved through Switches 2 & 3 of DS1. Switches 1 and 4 are not used.

Two additional labels are included in the package, one for 3 hours duration (180) and one for 8 hour duration (480). Depending on the selected duration, the installer must cover the default 1 hour (60) printing with one label that has the required duration. Please take notice of the orientation of the label.

Pass the mains cable through the hole and connect them to the terminal blocks. L for live wire N for neutral. The ground terminal is for termination purposes only.

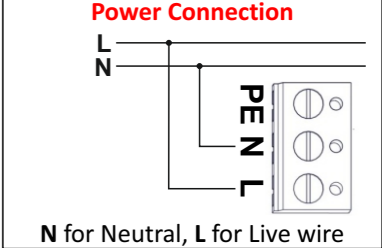

### Battery Connection

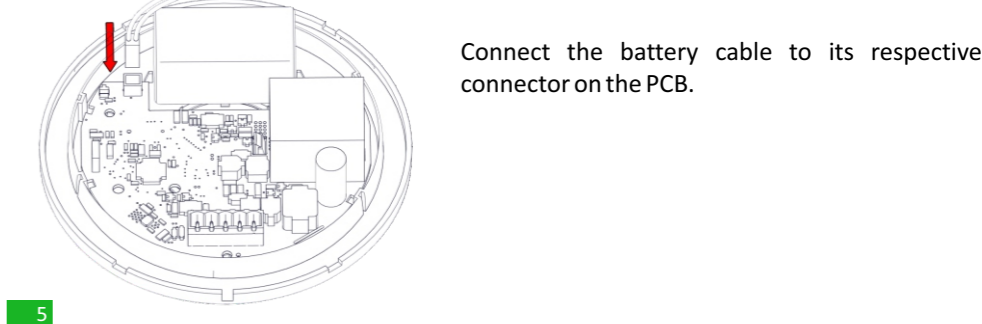

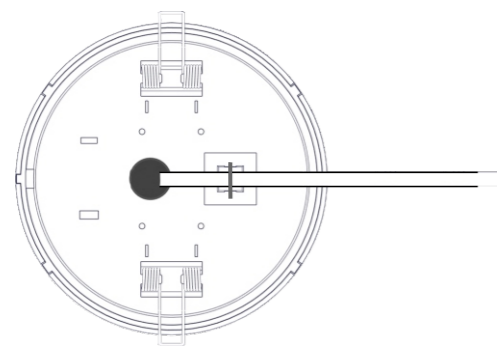

Refit the luminaire to the bottom cover. Clean the luminaire's surface, install the included tie-wrap to the included adhesive tether loop and fasten securely the power cable in order to anchor it.

6

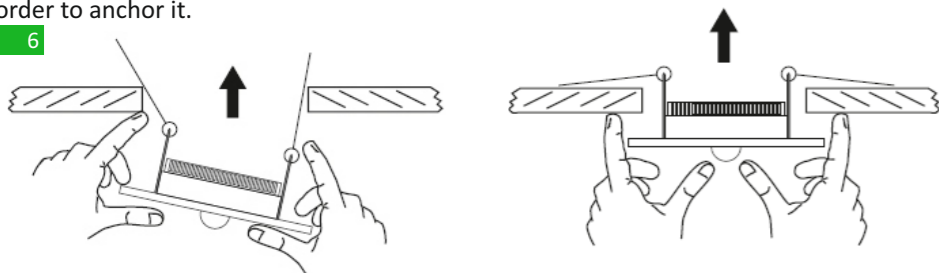

Bend one spring, to get into the holes of the suspended ceiling. Bend the other spring and push the luminaire upwards until it is securely mounted. The device is now ready to operate.

7

**NOTE!!**  
After finishing the installation you must power the luminaire for at least 24 hours in order to completely charge the battery. The rated autonomy duration can be achieved after that time.

### Battery Replacement

It can be done only by a competent person and after the mains interruption.

1. Disconnect mains, carefully remove the luminaire from the suspended ceiling, make sure that the springs do not snap.
2. Remove the bottom cover (step 2 of installation procedure).
3. Disconnect the battery and install a new one of the same type and characteristics.
4. Refit the cover.

#### Important notice for the installed luminaires in one area !!!

The installer must connect the battery's connector first and then should power the luminaire.

The time between batteries connection must be, at least 1.5 minute.

With this variation, it is ensured that the non synchronized Automatic Autonomy Test for two or more luminaires installed in one area, is not conducted in the same day.

**Note:** In case of mains power disconnection for a period of more than two months, the battery must be disconnected.

**Note:** In case of battery replacement, this must be replaced with parts of the same type and characteristics. The replacement must be performed by the manufacturer or a competent person.

**Note:** If the supply cable of the luminaire is damaged, it shall exclusively be replaced by a competent person in order to avoid hazard.

#### ATTENTION

The light source of this luminaire is not user replaceable. When the light source reaches its end of life the whole luminaire shall be replaced.



**CAUTION : Do not view directly with bare eyes.**

**NOTE: LED= Light Emitting Diode**

#### LABELING EXPLANATION:

X: Self contained

0: Non maintained operation (\*)

A: Including test device

E: With non-replacable lamp(s) and/or battery

F: Automatic test gear complying with IEC 61347-2-7 denoted EL-T

60: 60 minutes duration

180: 180 minutes duration

480: 480 minutes duration

(\*) **Non Maintained operation:** The luminaire lights its illumination source, only in power supply's failure.

X|0|A|E|F|60

4

923796000\_09\_001

### Technical Characteristics

GR-796/ST/DUO	
OPERATION VOLTAGE	220-240V AC / 50-60Hz
MAXIMUM POWER CONSUMPTION	3.3W / 3.8VA
MAX. SUPPLY CURRENT	17mA
MINIMUM POWER FACTOR (λ)	0.87
U-OUT	5V
Prated/Irated	1.9W / 650mA
INSULATION BETWEEN SUPPLY & CONTROL TERMINALS	Basic Insulation
INSULATION BETWEEN SUPPLY & BATTERY CIRCUIT	Basic Insulation
WORKING VOLTAGE AT WHICH THE INSULATION IS DESIGNED	500V
WIRE CROSS SECTION	2.5mm <sup>2</sup> (stranded) 4mm <sup>2</sup> (solid)
BATTERY (NiMH, 4HRMU15/15)	4.8V / 1.7Ah
CHARGE TIME	24 hours
BATTERY PROTECTION	Deep discharge and overcharge protection The control gear will recharge the battery normally after the test of 22.3
BATTERY SUPPLY CURRENT DURING EMERGENCY (Vbat=4.8V):	1h: 400-550mA, 3h: 290-405mA, 8h:125-170mA
BATTERY CHARGE CURRENT RANGE	110-135mA
BATTERY DISCHARGE CURRENT RANGE	130-550mA
MINIMUM DURATION	1, 3, 8 hours manually selected (default 1h)
LIGHT SOURCE	1 White Power LED
EMERGENCY ILLUMINATION	1h : 300lm 3h : 240lm 8h : 110lm
INDICATIONS	Charge - Fault (Lamp/Battery)
PRODUCED IN ACCORDANCE WITH	EN 60598-1, EN 60598-2-22, EN 55015 EN 61547, EN 61000-3-2, EN 61000-3-3
OPERATION TEMPERATURE RANGE	5 to 40°C
CONTROL GEAR MAX. TEMPERATURE:tc	80°C at LD4
DEGREES OF COVER PROTECTION	IP40
RELATIVE HUMIDITY	Up to 95%
CONSTRUCTION MATERIAL	ABS/PC
EXTERNAL DIMENSION (L x W x H)	ø130 x 37mm
WEIGHT	330gr.
GUARANTEE	3 years (1 year for the battery)

CONTROL GEAR WITH AUTOMATIC TEST FUNCTION

EL-T

Controlgear classification in accordance with IEC 62034: with automatic test function

The controlgear has mains-connected windings of transformer

The controlgear is proof against supply voltage polarity reversal

### LED Characteristics

MANUFACTURER	Olympia Electronics S.A.
MODEL NUMBER	1303225
VOLTAGE RANGE	2.7-2.95V
NOMINAL POWER	1.95W
CONNECTIONS	Built-in main board
TEMPERATURE (tc)	55°C max. across the board
LED Module Type	BUILD IN

### Warranty

Olympia Electronics guarantees the quality, condition and operation of the goods. The period of warranty is specified in the official catalogue of Olympia Electronics and also in the technical leaflet, which accompanies each product. This warranty ceases to exist if the buyer does not follow the technical instructions included in official documents given by Olympia Electronics or if the buyer modifies the goods provided or has any repairs or re-setting done by a third party, unless Olympia Electronics has fully agreed to them in writing. Products that have been damaged can be returned to the premises of our company for repair or replacement, as long as the warranty period is valid.

Olympia Electronics reserves the right to repair or to replace the returned goods and to or not charge the buyer depending on the reason of defection. Olympia Electronics reserves the right to charge or not the buyer the transportation cost.



72nd km. O.N.R. Thessaloniki-Katerini  
P.C. 60300 P.O. Box 06 Eginio Pierias Greece

[www.olympia-electronics.com](http://www.olympia-electronics.com)  
[info@olympia-electronics.gr](mailto:info@olympia-electronics.gr)

5



## GR-796/ST/DUO

SELF TESTING RECESSED  
NON-MAINTAINED EMERGENCY  
CEILING MOUNTED LUMINAIRE

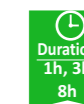

Thank you for your trust in our products  
Olympia Electronics - European manufacturer

923796000\_09\_001