



# GR-9500

## 230V Central Battery System



**Installation  
Programming  
Use**

**WARNING!!! PLEASE READ THE MANUAL CAREFULLY BEFORE INSTALLING**



*for a safer world!*

Date	9/5/2022
Document	923950003_09_010
Document code	923950003_09_010
Page	2 from 39

## Contents

<b>1. General information</b>	<b>4</b>
1.1 Technical Characteristics	5
<b>2. Installation</b>	<b>6</b>
2.1 Designing the installation	6
2.2 Connecting luminaires on illumination zones	6
2.3 Connecting the batteries	7
2.4 Describing the general inputs and outputs of the panel	8
2.5 Powering On	10
<b>3. Indicators - Controls</b>	<b>11</b>
<b>4. Programming</b>	<b>12</b>
4.1 Programming using the keypad	12
4.1.1 Programming the Zones	12
4.1.2 Programming Timers	13
4.1.3 General settings	15
4.1.4 Clearing Events	16
4.1.5 Change Code	17
4.1.6 Current setting	17
4.1.7 Inhibit mode	17
4.1.8 Programming the function test	17
4.1.9 Programming the capacity test	18
4.1.10 Capacity test	19
4.1.11 Reset Defaults	19
4.1.12 Annual Test	19
4.1.13 Network Setting	19
4.2 Programming via PC	21
4.2.1 Programming the zones	22
4.2.2 Programming timers	22
4.2.3 Programming the battery capacity and the autonomy	23
4.2.4 INHIBIT function	23
4.2.5 Adjusting the date and time	23
4.2.6 Battery cooler	24
4.2.7 Change Language	24
4.2.8 Staircase time	24
4.2.9 Clearing the events log	25
4.2.10 Changing the tech code	25



*for a safer world!*

Date	9/5/2022
Document	923950003_09_010
Document code	923950003_09_010
Page	3 from 39

4.2.11	Network of panels .....	26
4.2.12	Subpanel Setup .....	26
4.2.13	Set the current of the zones .....	27
4.2.14	Function test .....	27
4.2.15	Capacity test .....	27
4.2.16	Programming the function test .....	28
4.2.17	Programming the capacity test .....	28
4.2.18	Programming the annual check warning .....	28
4.2.19	Annual Test OK .....	29
4.2.20	Setting Defaults .....	29
4.2.21	Changing information .....	29
4.2.22	IP address .....	30
4.2.23	Resetting faults .....	30
<b>5.</b>	<b>Use .....</b>	<b>31</b>
5.1	Operation using the keypad .....	31
5.1.1	Test .....	31
5.1.2	Information .....	33
5.1.3	Reset .....	34
5.1.4	All Events .....	34
5.1.5	Earth Test .....	35
5.1.6	LED test .....	35
5.2	Operation via PC .....	35
5.2.1	Panel Information .....	35
5.2.2	Zone programming information .....	36
5.2.3	Zones status information .....	36
5.2.4	Timer information .....	36
5.2.5	Function test results .....	37
5.2.6	Capacity test results .....	37
5.2.7	Last autonomies .....	37
5.2.8	All events .....	38
5.2.9	Network information .....	38
5.2.10	Panels network .....	38

  <p><i>for a safer world!</i></p>	Date	9/5/2022
	Document	923950003_09_010
	Document code	923950003_09_010
	Page	4 from 39

**Thank you for your trust in our products  
Olympia Electronics - European manufacturer**

## 1. General information

The GR-9500 family consists of 3 models of central battery systems for emergency illumination. They are produced in accordance with the current European norms EN50171 and EN50172. Depending on the model, they contain 4 to 8 illumination circuits and each can be individually programmed to operate as maintained or non-maintained. In the maintained illumination circuits a 230VAC voltage is provided from the mains power supply when the power supply is active. In case of an interruption of the mains power supply, the illumination circuits are provided with 230VAC powered by an inverter which is supplied from the batteries. The interior of the panel is divided into 2 compartments, the electronics compartment and the batteries' compartment. A sensor monitors the batteries' temperature continuously.



*for a safer world!*

Date 9/5/2022

Document 923950003\_09\_010

Document code 923950003\_09\_010

Page 5 from 39

## 1.1 Technical Characteristics

	GR-9500/300/4	GR-9500/300/8	GR-9500/600/8
Operating voltage	~220-240V 50-60Hz		
Batteries	2 x12V/33Ah		2 x 12V/55Ah
Illumination circuits (Zones)	4	8	8
Maximum AC power (Input)	700VA		1kVA
Maximum AC power (Emergency)	300VA		600VA
Max. power output (per zone)	75VA		
Operating temperature range	5 – 40 °C		
Degrees of cover protection	IP 21		
Dimensions	67 x 50 x 27 cm		
Weight (w/o batteries)	18.5kg	18.9kg	20.5kg
Battery fuse	30A/32V (maxi)		
Zones fuse (Output)	1A/250V (fast)		
Zones fuse (Neutral)	3A/250V (slow)		
Mains fuse	8A/250V (slow)		
Battery fan fuse	0.3A/250V (slow)		
Type of electric shock protection	Class I		
Max. operating altitude (above sea level)	1000m.		
Max. relative humidity	95%		
Guarantee	2 years		

All fuses are 5x20 size, battery fuse is 29mm car type.

**WARNING:** This is a category C2 UPS product. In a residential environment, this product may cause radio interference, in which case the user may be required to take additional measures.

The class of Volt-meter and Ampere-meter is 1.5.



for a safer world!

Date	9/5/2022
Document	923950003_09_010
Document code	923950003_09_010
Page	6 from 39

## 2. Installation

This section contains information that concerns the designing of the installation, the connection of the panel with the luminaires and the use of the auxiliary outputs and inputs. The instructions must be read carefully by the installer that is set to commission the panel. Skill and knowledge about the panel as well as its peripherals is essential for the good operation of the installation.

**All the connections described below must be done with the 230VAC main power supply isolated and the battery fuse removed.**

### 2.1 Designing the installation

Before starting to install the cable you must take into account some critical parameters.

- All the luminaires that are connected to an illumination zone operate with the same method. They are either maintained or non-maintained.
- The cable that will be used must be resistant to fire for at least 90 minutes. A suitable type is NHXH FE180/E90.
- The cable cross section depends on the consumption of the luminaires on the zone and the total length of the zone cable. The calculation of the cross section is the same as typical electrical luminaires connection. A typical cross section is 1.5mm<sup>2</sup>.
- There is an option for wall mounting the panel with the correct accessories. Please refer to manufacturer for further information for wall mounting.

### 2.2 Connecting luminaires on illumination zones

The connection of the luminaires is the same as common luminaires. Below you can see an example:

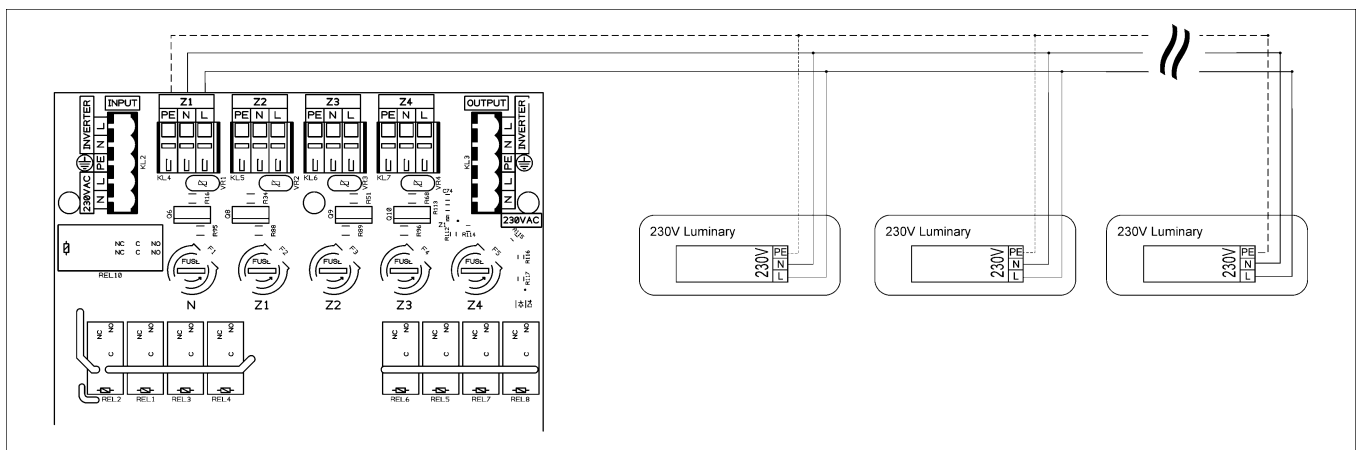

The "PE" line is connected when the luminaire includes a "PE" (Earth) contact.

**All connections to the illumination zones as well as any other modifications afterward require that the mains power supply is isolated and that the battery fuse is removed.**



Date	9/5/2022
Document	923950003_09_010
Document code	923950003_09_010
Page	7 from 39

### 2.3 Connecting the batteries.

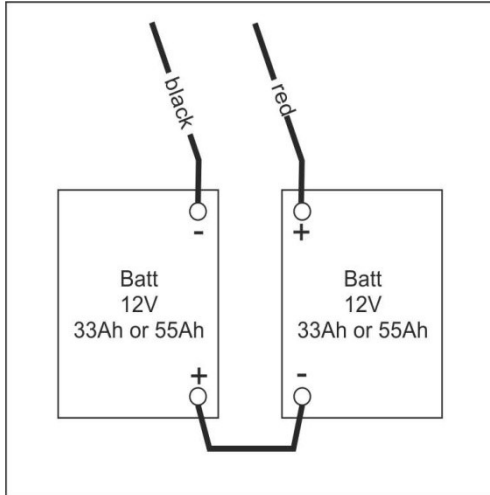

We recommend using the following types of batteries: A-1200 (12V/33Ah), A-1202 (12V/55Ah). The above types of batteries are designed for Central Battery Systems (CBS) and the declared life expectancy is at least 10 years at 20°C ambient temperature.

First remove the battery fuse from its socket. The batteries must be connected in series. In the batteries' compartment can be found 2 cables, one red and one black. There must also be a short cable (12cm black) contained in the package with two hole terminals on its ends. The red cable must be connected to the positive pole of the 1<sup>st</sup> battery and the black cable must be connected to the negative pole of the 2<sup>nd</sup> battery. The 3<sup>rd</sup> short cable must be used to connect the negative pole of the first battery to the positive pole of the second battery.

**Warning!! Do not install the battery fuse in this phase.**

**Warning!! In case of wrong battery polarity and battery fuse is plugged in DO NOT turn off the main switch before removing the**

**battery fuse.**

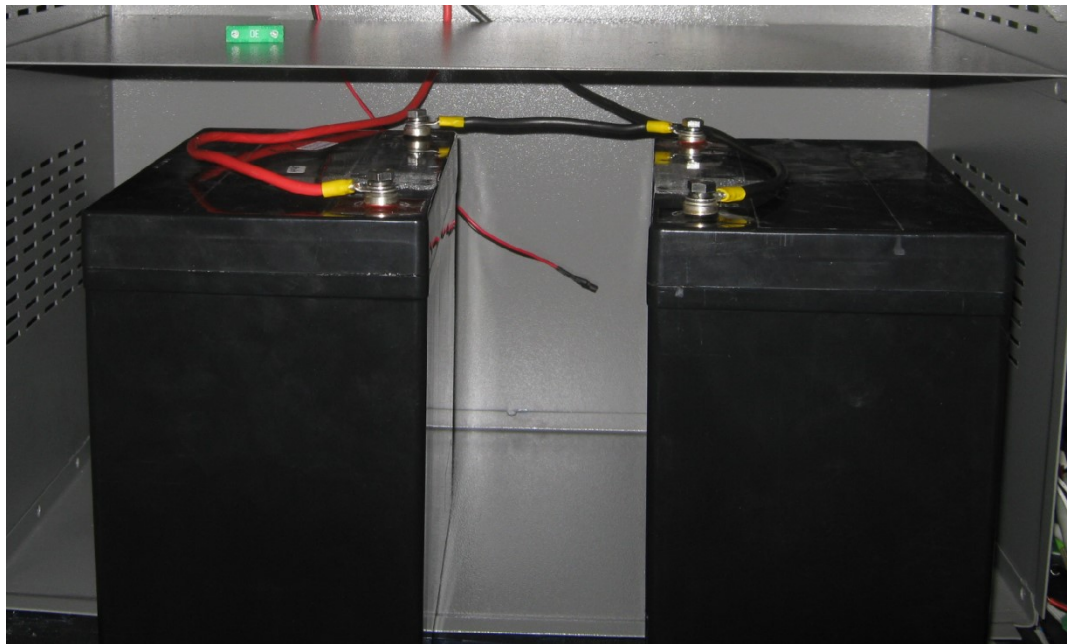

-Batteries compartment-



## 2.4 Describing the general inputs and outputs of the panel

On the printed circuit board located to the left side of the panel you can see the general purpose input and output terminal blocks. The figure below shows the terminals of the circuit board and they are described from left to right.

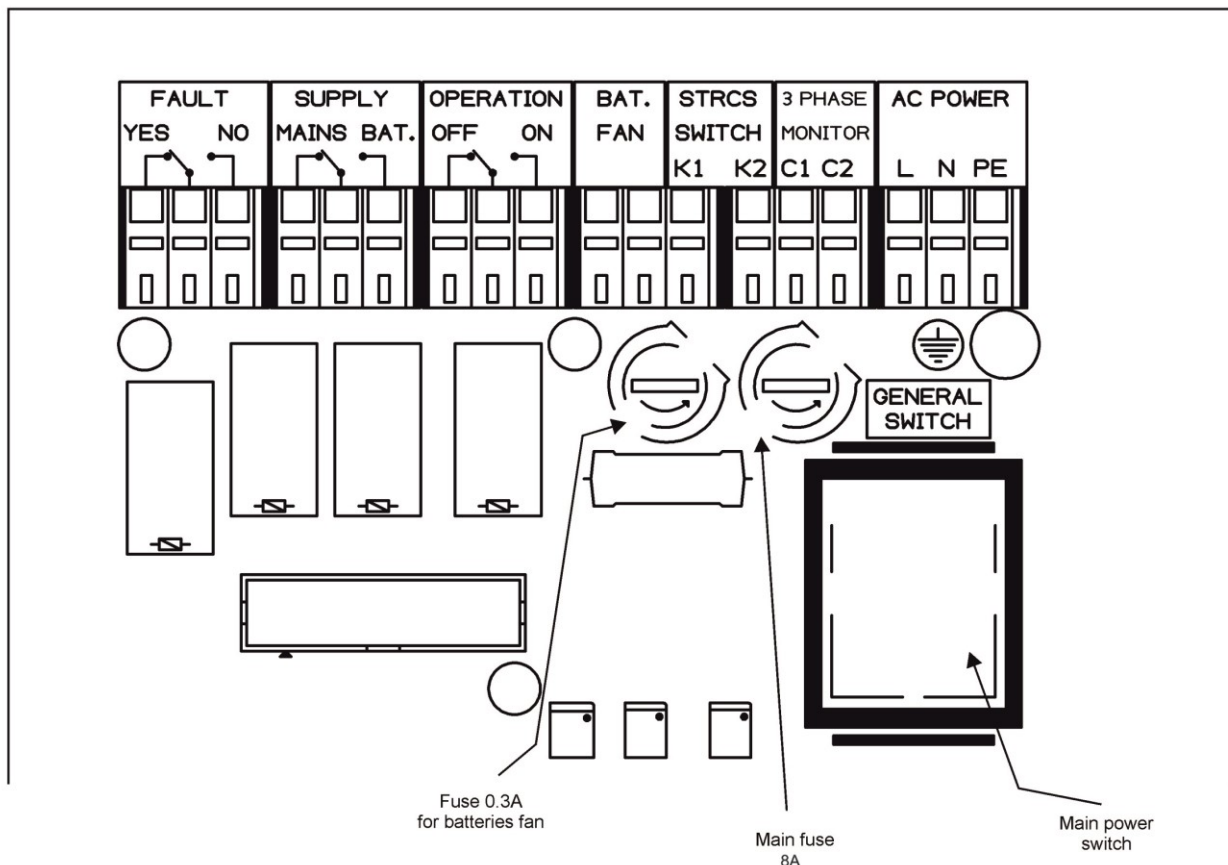

The next 3 outputs are relay outputs that are mandatory by the European norms. These outputs are connected to the building BMS and relay that require information regarding the status of the central battery illumination system.

**FAULT YES / NO.** Fault relay contact. When there is no system fault, the NO contact is active otherwise the YES contact is active.

**SUPPLY MAINS / BAT.** Relay contact that shows what type of power is supplying the system. When the power is supplied by the batteries then the BAT contact is active. When it is powered from mains, the MAINS contact is active.

**OPERATION OFF / ON.** Relay contact indicating the operation status of the panel. When the panel is operating, the ON contact is active. When the panel is shut down or is in cut-off mode the OFF contact is active.

The next 4 outputs-inputs are not relay contacts and they are supplied by live voltage so safety has to be considered when connecting those terminals. Don't connect the mains power cord before completing the following connections (if any).

**BATT FAN.** Terminal block for connecting AC230V cooling fan. (fuse 0.3A/250V slow)



*for a safer world!*

Date	9/5/2022
Document	923950003_09_010
Document code	923950003_09_010
Page	9 from 39

**STRCS SWITCH.** This input is used to connect in parallel, common staircase light buttons. By programming, some illumination zones can be activated for a pre-programmed time period by pressing one of the staircase light buttons.

**3 PHASE MONITOR.** This contact by default has a jumper installed. When the contact is open then the panel activates the emergency luminaries. By using one or more mains voltage monitors we can activate the emergency light circuits even when the mains power to the panel is still on. It can also be used as a trigger input that is controlled by a higher level building management system which can give a command for the emergency illumination to turn ON.

Below you can see the connection with 3 mains voltage monitoring devices connected to individual electrical panels.

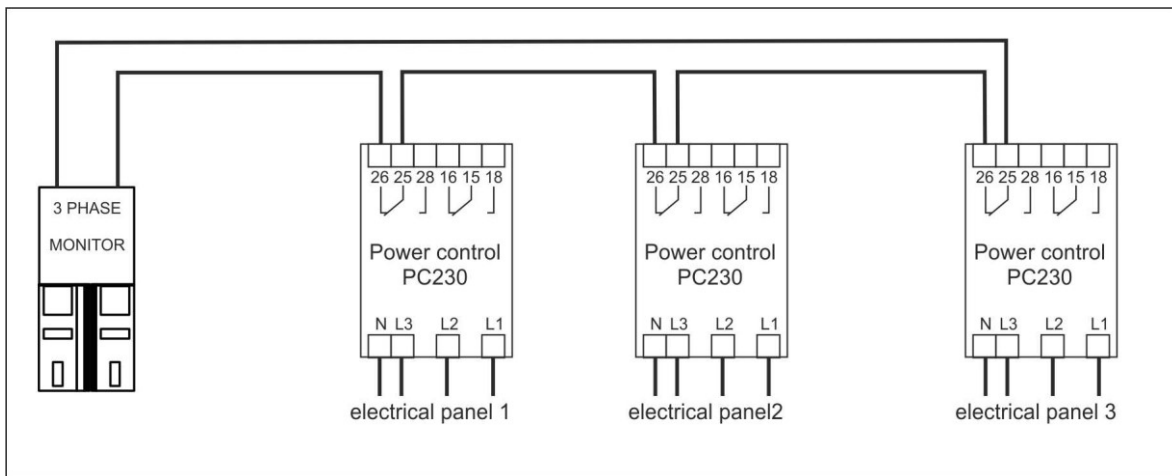

If any phase on any electrical panel fails then a command is sent and the emergency illumination is turned ON.

**AC POWER.** Mains AC power connection terminal. **It is suggested to do this connection after all the other connections are finished. WARNING!! Connect the supply accordingly to the indications L – N – PE. The polarity is crucial for the normal operation and the user's safety.**



Date	9/5/2022
Document	923950003_09_010
Document code	923950003_09_010
Page	10 from 39

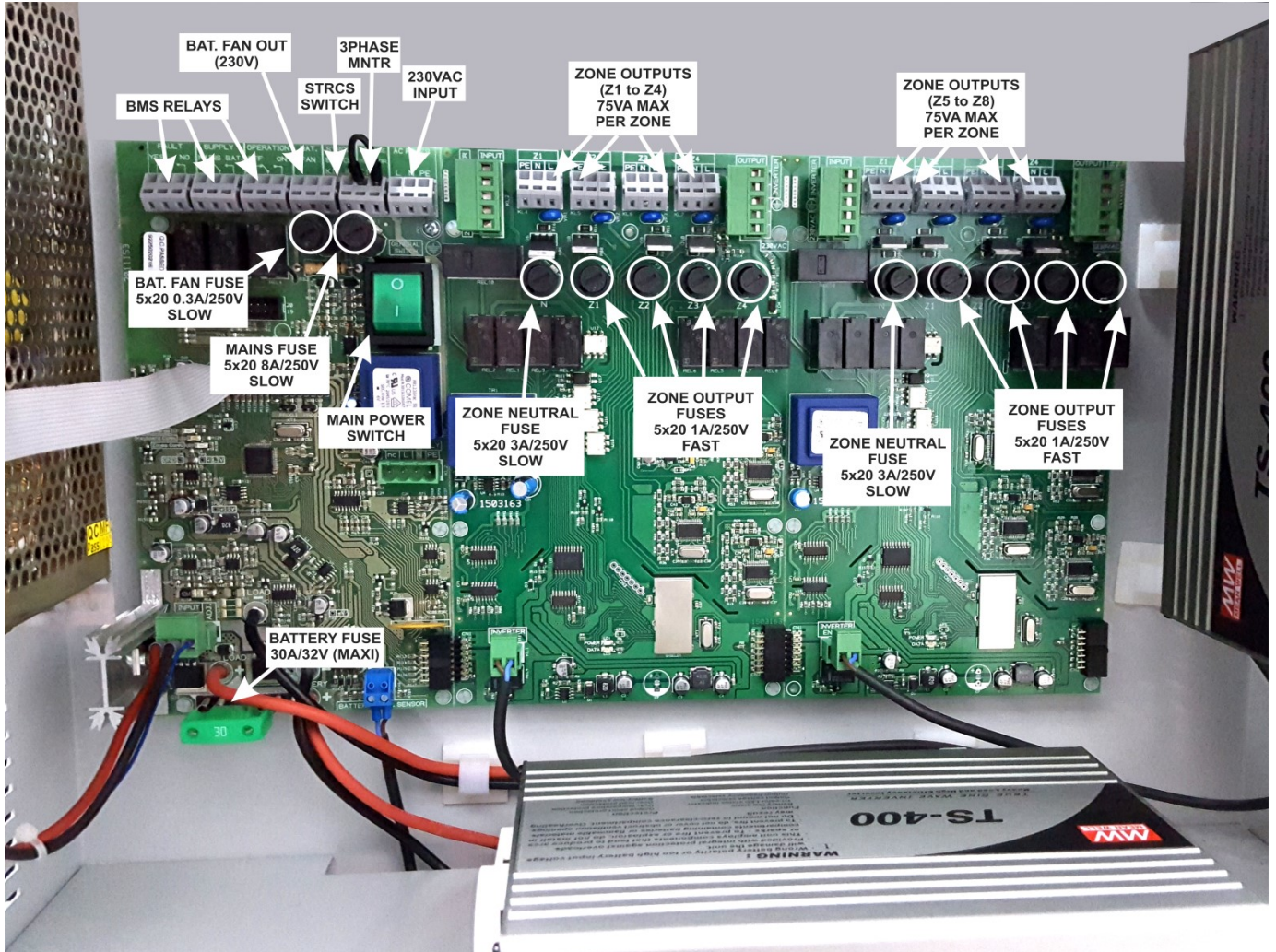

-Interior of a GR-9500 (8 Zones)-

## 2.5 Powering On

Before powering on the device, reassure that the batteries and the mains power cord are connected with **correct polarity** and the battery fuse is **unplugged**. Then turn on the green switch (**mains power switch**).

The switch must light on and the panel starts up. The system goes on a brief self test while the message "CBS-230, Ver.2.xx, PLEASE WAIT" appears on screen. When it's done, main screen appears. It's now safe to plug the battery fuse (30A). The fault "BATTERY, FUSE FAULT" should appear on screen, but it will disappear in a minute or less from the time the battery fuse is plugged in.



Date	9/5/2022
Document	923950003_09_010
Document code	923950003_09_010
Page	11 from 39

### 3. Indicators - Controls

The panel has the following controls and indicators.

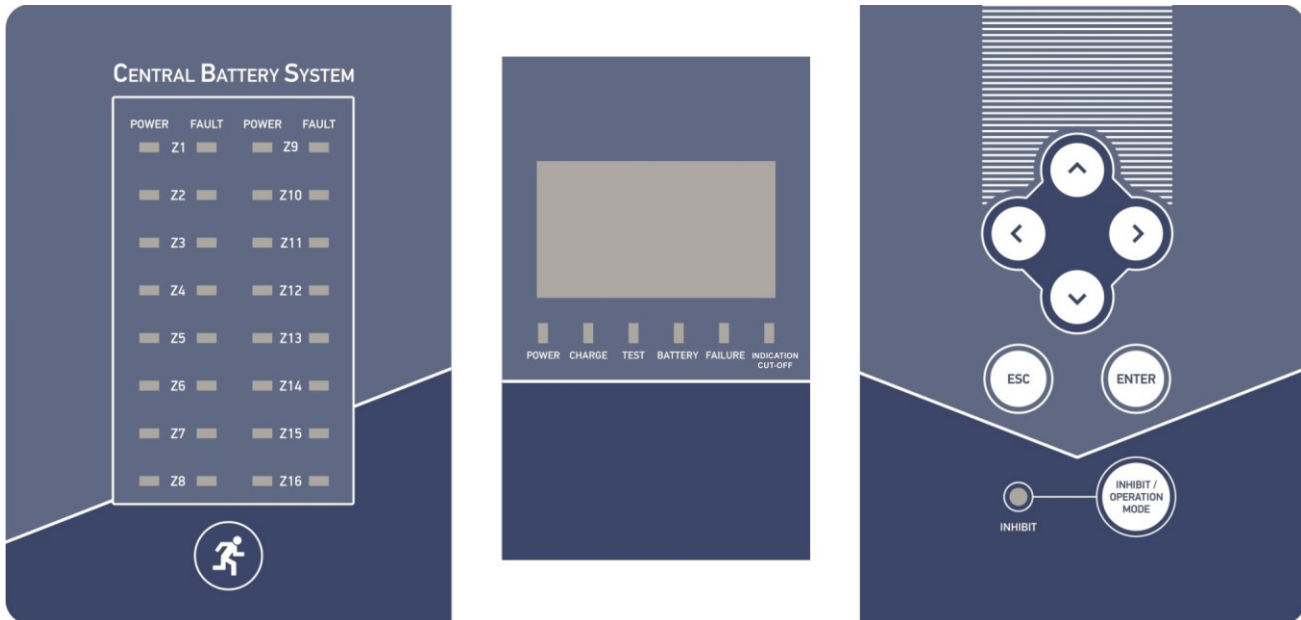

On the left section of the front face there are LED indications which show the status of the zones:

The green LED next to each zone, lights on continuously when the zone is installed and is supplied by mains voltage. When the green LED blinks, the zone is supplied by the 230VAC inverter which is powered by the batteries. Green LED blinking occurs in emergency mode or in test function mode. When the green LED is off, the zone is either not installed or set on "OFF" mode.

The red LED next to each zone lights on when there is a fault on the specific zone (like fuse fault, or current fault, etc).

On the middle section of the panel there is the system screen and some indication LEDs which are described below:

**POWER.** A green LED which is lit when the panel has a 230VAC (mains) power supply.

**CHARGE.** A green LED which is lit when the batteries of the panel are charging.

**TEST.** An orange LED which is lit during a function test procedure or a capacity test.

**BATTERY.** An orange LED which is lit when the illumination output circuits are powered by the batteries.

**FAILURE.** An orange LED which is lit when at least one system error has occurred.

**INDICATION CUT-OFF.** An orange LED which is lit when the batteries' voltage is low and cut-off is about to take place in a few minutes.

On the right section of the front face there is a group of buttons (keypad) and the **INHIBIT** indication LED.

**INHIBIT LED.** A green LED which is lit when "inhibit" mode is active. **In this state, the panel charges the batteries but does not enter emergency operation**, meaning that the zones' output is inactive when the mains power fails. This is useful for buildings that are not used for long periods of time.

The **INHIBIT** button next to the LED has a toggle function. It will change the state between "NORMAL" and "INHIBIT" and vice versa in every push.

Above the "inhibit" button, there are 6 main buttons used for the programming and control of the panel. The buttons with the arrows (up/down/left/right) are used to navigate, select and increase/decrease a variable. "Enter" button is used for selecting an option and "Esc" is for rejection or returning to the previous state.



for a safer world!

Date	9/5/2022
Document	923950003_09_010
Document code	923950003_09_010
Page	12 from 39

## 4. Programming

The programming of the panel can be done using the keypad and the screen. Alternately it can be done using a PC through an Ethernet connection. In case of a network of panels, some settings can only be done using a PC.

### 4.1 Programming using the keypad

By correctly completing the whole installation, after powering on the system, the screen on the right should appear.

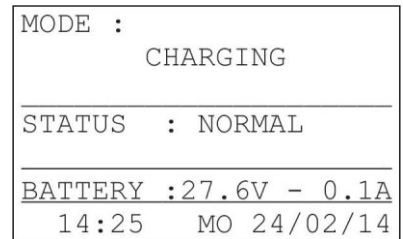

If “Enter” key is pressed the next screen shows up (MENU). Press the down arrow until the cursor goes to the selection TECHNICIAN MENU and select by pressing the “Enter” key again.

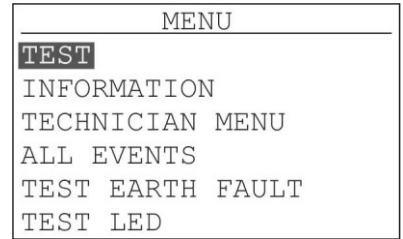

For safety reasons, programming can be done only by personnel that know the technician code. To enter the code, use the arrow keys. Use the up/down arrow keys for increasing/decreasing the value and the right/left keys to go to the next or previous digit. When the code is entered press Enter.

The factory default code for the Technician Menu is “1000”.

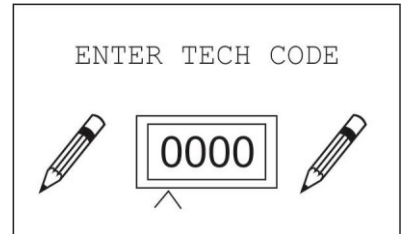

#### 4.1.1 Programming the Zones

If a correct code is given and the “Enter” key is pressed the Technician Menu screen is shown, else an error is displayed. The Technician Menu also has some additional settings that can be shown if you scroll down pressing down arrow. These are MODE INHIBIT, SET FUNCTION TEST, SET CAPACITY TEST, MAKE A CAPACITY TEST, RESET DEFAULTS, ANNUAL CHECK DONE, and NETWORK.

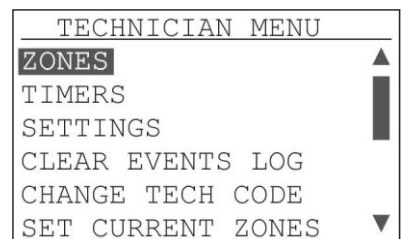

With the cursor on the ZONES setting press the “Enter” key and the next screen is shown. With the up/down keys select the required zone and press the “Enter” key. For 2 seconds the name of the zone appears.

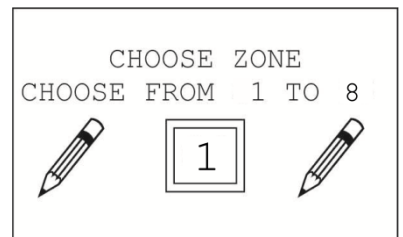



*for a safer world!*

Date	9/5/2022
Document	923950003_09_010
Document code	923950003_09_010
Page	13 from 39

First select if the zone is installed or not. NO is selected only if the zone is not physically installed. With the selection NO the panel returns to the TECHNICIAN MENU.

If you select YES you proceed to program the operation of the zone. If you select YES for a zone that is not physically installed then the programming will be done but after a while an error message "NOT CONNECTED" will be shown on the main screen.

INSTALLED	
NO	<input checked="" type="checkbox"/>
YES	<input type="checkbox"/>

Select the operation method using the Up/Down keys and press "Enter".

MAINTAINED means that the luminaires that are connected on this zone will operate permanently.

NON-MAINTAINED means that the luminaires on the zone will only operate in emergency mode or in test.

OFF means that this zone will never operate.

By default all zones are set to NON MAINTAINED operation.

ZONE MODE	
MAINTAINED	<input type="checkbox"/>
NON MAINTAINED	<input checked="" type="checkbox"/>
OFF	<input type="checkbox"/>

The current monitor is used in the function test. During the current setting procedure (see 4.1.6), the current that is drawn on each zone is logged. If you select one of the available rates, in every functional test the measured current will be compared to the logged current and if it is out of range more than the selected percentage then the panel will show a message for the specific zone. Current monitor is a tool that can even locate individually malfunctioning luminaires on a zone.

For example, if you connect up to 10 similar luminaires on a zone and you set current monitoring to 5%, each luminaire that will not light in a function test will lower the current consumption by 10% and the system will detect an error on that zone. The user that sees the error can conduct a manual function test and confirm which luminaire is not operating.

If the zone has been set to operate as MAINTAINED then the system urges us to select a timer. Timers are used to turn OFF or ON luminaires at specific hours when people are not in the building. For this programming see par. 4.1.2.

By default the setting NO TIMER is selected for all zones.

CURRENT MONITOR	
5%	<input type="checkbox"/>
10%	<input type="checkbox"/>
20%	<input type="checkbox"/>
50%	<input type="checkbox"/>
OFF	<input checked="" type="checkbox"/>

If the zone has been programmed to operate as NON MAINTAINED then you are urged to select if you want a staircase operation. If you select YES, then when a button that is connected to the terminal "STRCS SWITCH" is pressed, the luminaires of the zone will light for a time that has been set in the setting STAIRCASE TIME (see 4.1.3) and afterward they will go OFF. The default setting is NO for all zones.

CHOOSE TIMER	
NO TIMER	<input checked="" type="checkbox"/>
1	<input type="checkbox"/>
2	<input type="checkbox"/>
3	<input type="checkbox"/>
4	<input type="checkbox"/>
5	<input type="checkbox"/>

STAIRCASE FUNCION	
NO	<input checked="" type="checkbox"/>
YES	<input type="checkbox"/>

#### 4.1.2 Programming Timers

Timers are used to automatically turn OFF the luminaires connected to MAINTAINED zones when there are no people in the building. This way you can save power without degrading the safety level of the building. Even if a zone has been turned OFF by a timer, during a mains power failure the luminaires connected to the zone will light.



*for a safer world!*

Date	9/5/2022
Document	923950003_09_010
Document code	923950003_09_010
Page	14 from 39

Select **TIMER** option and press “Enter”, then the next screen shows up. With the Up/Down keys you can change the timer. Press “Enter” once the required timer has been selected.

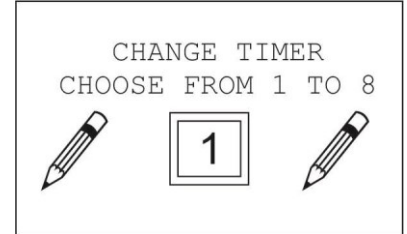

By default, all timers are deactivated. To program a timer you must first activate it by selecting the option **ACTIVE** and pressing “Enter”.

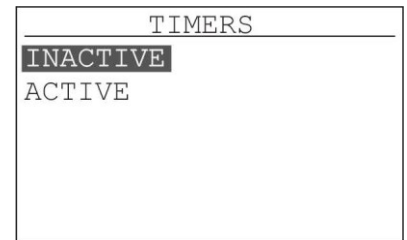

Select the start time of the Timer (this is the hour that the luminaires will be turned ON). With the Up/Down keys you can change the digit value and with the Right/Left keys you can select the digits. In order to save the time press the right key past the last digit.

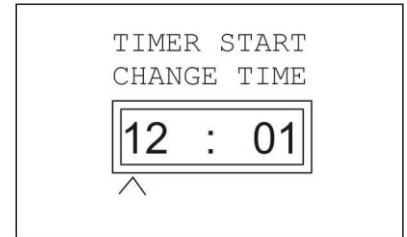

Select the start week day of the timer. With the selection **EVERY DAY** the timer will repeat daily. There are available also **WEEKEND** and **WEEK DAY** options.

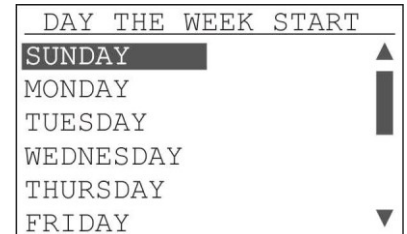

Select the stop time of the Timer (this is the hour that the luminaires will be turned OFF). With the Up/Down keys you can change the digit value and with the Right/Left keys you can change the digits. In order to save the time press the right key past the last digit.

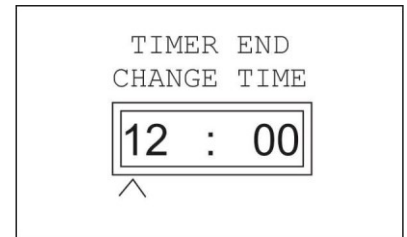

Select the end week day of the timer. If you have previously selected **EVERY DAY** or **WEEKEND** or **WEEK DAY** then this screen will not be shown.

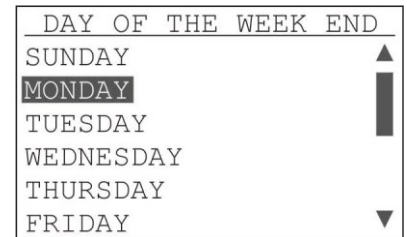

### 4.1.3 General settings

By selecting SETTINGS and then pressing “Enter” the next screen is shown. The SETTINGS menu includes some additional options that can become visible by scrolling down the menu with the “down” key. These are SELECT LANGUAGE, ANNUAL CHECK WARNING, STAIRCASE TIME, BATTERY COOLER and MENU MANUFACTURER.

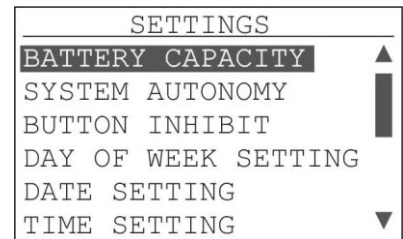

By selecting BATTERY CAPACITY and pressing “Enter” you see the next screen. The batteries that can be used are 33Ah or 55Ah. Using the up/down keys select the required capacity and press “Enter”.

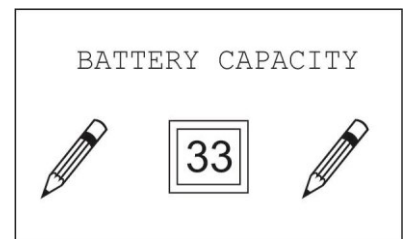

By selecting SYSTEM AUTONOMY and pressing “Enter” you see the next screen. Using the up/down keys you can select one of the five options available. Press “Enter” when finished. **With this selection you do not actually change the autonomous duration of the panel.** You only inform the system of the required emergency duration so it can use it in future autonomous duration test. **The actual duration must be calculated before the installation by calculating the consumption of the luminaires in emergency operation and selecting the appropriate batteries.** The calculated duration must be equal to or greater than the required.

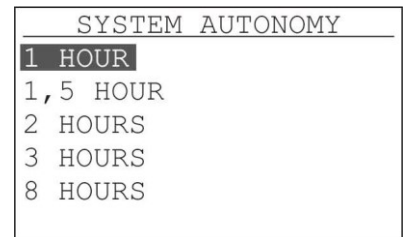

By selecting the BUTTON INHIBIT and pressing “Enter” you can see the next screen. There you can set whether the INHIBIT key is functional or not. The functions of the INHIBIT key can be seen in par. 3. Sometimes for safety reasons it is required that the INHIBIT key is not functional. In this case select NO and press “Enter”. By default BUTTON INHIBIT is set to YES.

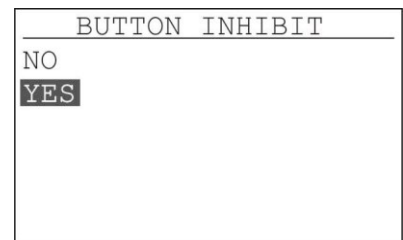

With the next 3 functions you can modify the date and hour. This must be done during the installation to enable all logged events to have the correct time and date stamp.

By selecting the CHANGE DAY and pressing “Enter” you can see the following screen on the right. Select the current day of the week using the up/down key and press “Enter”.

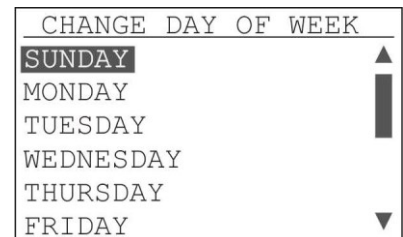

By selecting DATE SETTING and pressing Enter you see the screen on the right. With the up/down keys you can change the value of each digit. With the left/right keys you can select each digit. Write the correct date and press “Enter”.

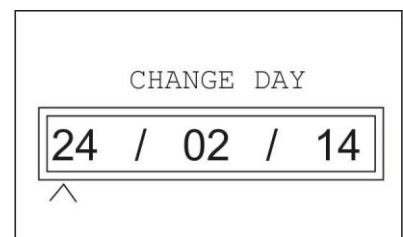

*Note that date format is day/month/year.*

  <p><i>for a safer world!</i></p>	Date	9/5/2022
	Document	923950003_09_010
	Document code	923950003_09_010
	Page	16 from 39

By selecting TIME SETTING and pressing “Enter” you can see the screen on the right. With the up/down keys you can change the value of each digit. With the left/right keys you can select each digit. In order to save the time press the right key past the last digit.

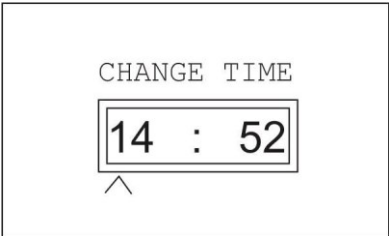

By selecting SELECT LANGUAGE and pressing “Enter” you can see the screen on the right. With the up/down keys select Greek, English or Norge and then press “Enter”. When changed, all logged events use the new language.

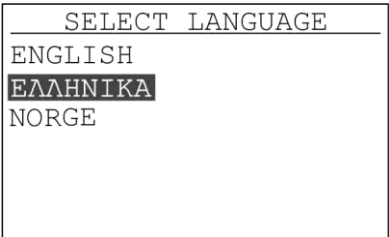

By selecting ANNUAL CHECK WARNING and pressing “Enter” you see the screen on the right. With the up/down keys select NO or YES and press “Enter”. If you select YES then every year you will be getting a reminding message about the Annual inspection.

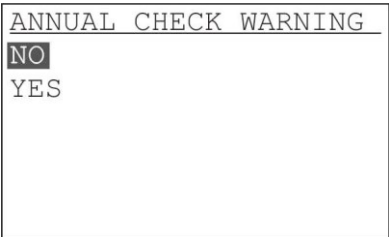

By selecting STAIRCASE TIME and pressing Enter you can see the screen on the right. With the up/down keys you can select the required minutes that the staircase light will remain on and then press “Enter”. The default value is 3 minutes.

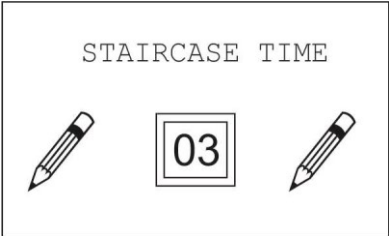

By selecting BATTERY COOLER and pressing “Enter” you can see the screen on the right. With the up/down keys you select NO or YES and then press “Enter”. The option YES **must only** be selected if a fan has been installed in the batteries’ compartment. Deactivated by default.

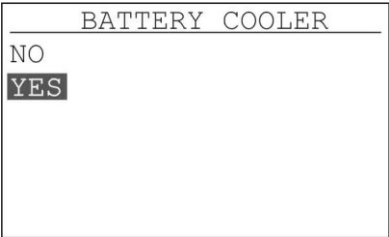

The MANUFACTURER MENU does not contain any option that can be adjusted by the installer.

**4.1.4 Clearing Events**

By selecting CLEAR EVENTS and pressing “Enter” you can see the screen on the right. The system requests a confirmation. If you actually need to clear the events then with the down key select YES and then press “Enter”. Clearing of event must be done after the initial installation has finished.

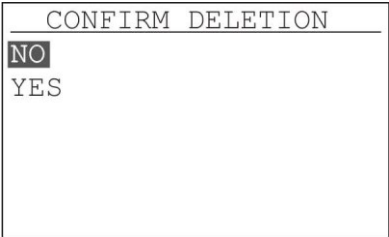

  <p><i>for a safer world!</i></p>	Date	9/5/2022
	Document	923950003_09_010
	Document code	923950003_09_010
	Page	17 from 39

#### 4.1.5 Change Code

By selecting CHANGE CODE and pressing “Enter” you can see the screen on the right. Using the up/down and right/left keys enter the correct code and press “Enter”. The new code is the one to be used for programming the system from PC also. Changing the technician code is an action that must be responsibly done. In case of a code loss, there is no way to reset the code to the previous one without knowing the current code.

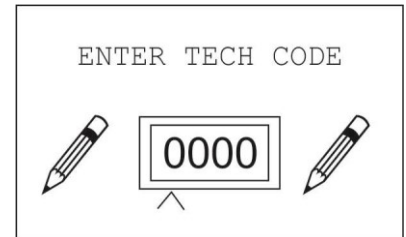

#### 4.1.6 Current setting

The current setting must be done when the installation has finished and when it has been determined that all luminaires are operating normally. It must also be done every time that a luminaire is added or removed from the installation. By selecting SET CURRENT ZONE and pressing “Enter” you can see the screen on the right. The procedure lasts for 90 seconds. After that, current consumption of each zone and the total battery discharge current is logged in system’s memory. This log will be used in every functional test so the panel can determine if a zone’s consumption or battery discharge current have changed unexpectedly, that could lead to a faulty luminaire or a faulty wiring between luminaires.

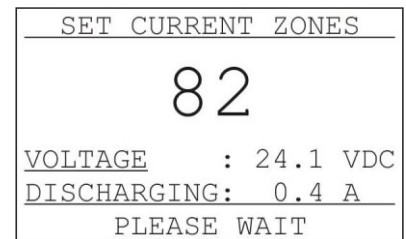

*In order for the system to compare a zone’s consumption, first the current monitor of that zone has to be set in a valid percentage (see 4.1.1).*

**Warning.** Before starting the procedure the batteries of the panel must be charged **at least to their 60% capacity**.

**Warning.** This procedure must be done every time a new luminary is installed.

#### 4.1.7 Inhibit mode

This selection sets the INHIBIT mode on/off.  
*About INHIBIT button, see par. 3.*

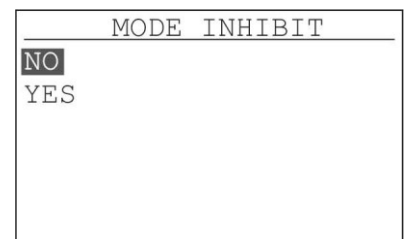

#### 4.1.8 Programming the function test

By selecting SET FUNCTION TEST and pressing “Enter” you can set the parameters for the automatic function test. The options are Daily, Every Other Day or once a week on a specific day. The duration of the test is 90 seconds. During this test all the luminaires are supplied by the inverter voltage (simulating a power failure). Battery discharge current and zones’ current consumption are compared to the values that were logged during “current setting” procedure. Select the required interval and press “Enter”.

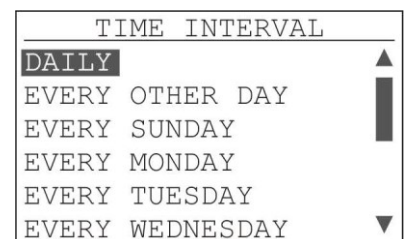



Date	9/5/2022
Document	923950003_09_010
Document code	923950003_09_010
Page	18 from 39

Now set the hour for the test. With the up/down keys you can change the value of each digit. With the left/right keys you can select each digit. In order to save the time press the right key past the last digit.

It is wise to program the function test to take place in hours and days when the building is not crowded or even closed so it does not interfere with other tasks. The default setting is 8:00 am every day.

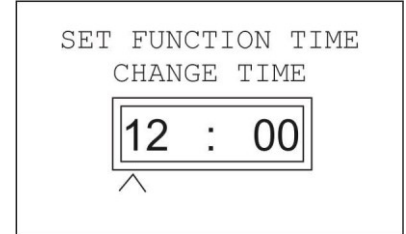

#### 4.1.9 Programming the capacity test

The capacity test procedure is able to determine if the required system autonomy can be achieved. There are 2 memory positions to adjust two different in time tests. The autonomy test must be done from once every 6 months to once a year. The autonomy test lasts for 2/3 of the stated autonomous duration of the system.

By selecting SET CAPACITY TEST and pressing "Enter" you see the screen on the right. Select the required test number, 1 or 2 and press "Enter".

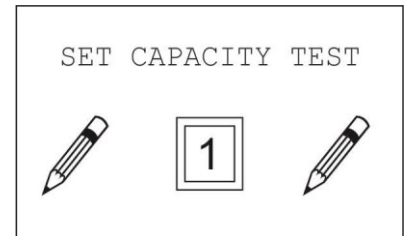

By default both tests are active. To continue select ACTIVE and press "Enter".

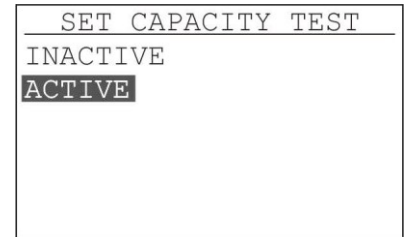

Select the desired date for the test using the arrow keys. The last 2 digits are for the year. Once the required date is set, press "Enter".

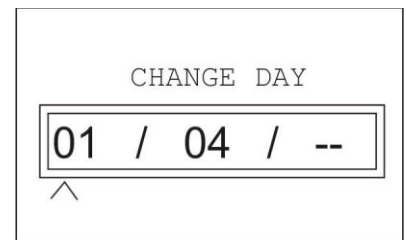

Select the hour for the test using the arrow keys.

You must select wisely the time and date of the capacity test because for the next 12 hours after the test finishes, the system will not achieve the stated autonomous duration due to batteries' discharging.

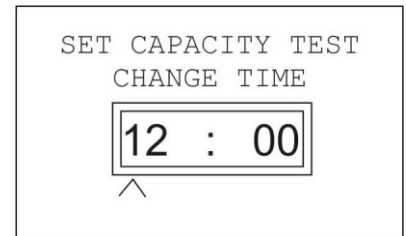



for a safer world!

Date	9/5/2022
Document	923950003_09_010
Document code	923950003_09_010
Page	19 from 39

#### 4.1.10 Capacity test

By selecting MAKE A CAPACITY TEST and pressing the “Enter” key the panel conducts a manual capacity test and you see the screen on the right. On the first line with the big letters you see the duration of the test. On the next 3 lines you can see the voltage of the batteries, the current that discharges the batteries and the capacity that has determined until this time.

**Warning. Before starting the procedure the batteries must be fully charged.**

MAKE A CAPACITY TEST	
<b>00:00:12</b>	
VOLTAGE	: 25.5VDC
DISCHARGING:	7.8 A
CAPACITY	: 0.000 AH
PRESS ESC TO RETURN	

The full capacity test lasts the 2/3 of the stated autonomous duration. You can leave the test to complete or stop it at any time with “Esc” key.

*Stated autonomous duration is set by the user. See par. 4.1.3*

CAPACITY TEST	
CANCEL CAPACITY TEST	

#### 4.1.11 Reset Defaults

To reset all settings to factory default, select RESET DEFAULTS and press “Enter”. When the message on the right is shown then the procedure has finished.

ACTION SUCCEEDED

#### 4.1.12 Annual Test

If you have finished with the annual tests and want to delete the related message, select ANNUAL TEST DONE and then press “Enter”. When the screen shows the message on the right then the related message has been deleted.

ACTION SUCCEEDED

#### 4.1.13 Network Setting

By selecting NETWORK and pressing “Enter” you see the settings for using the panel via an Ethernet connection. The panel can be connected to a network in order to cooperate with other panels or to be programmed by a computer. In order to operate a panel via a network, the Ethernet module has to be installed. It’s not installed by default, unless it has been ordered so. The Ethernet module is placed behind the main board on the front door (above locking mechanism).

NETWORK	
<b>ETHERNET PCB</b>	
IP ADDRESS	
RESET ETHERNET	



*for a safer world!*

Date	9/5/2022
Document	923950003_09_010
Document code	923950003_09_010
Page	20 from 39

If the panel has an Ethernet module installed then select ETHERNET CARD, press "Enter" and then select YES.

ETHERNET PCB	
NO	
<b>YES</b>	

If you select IP ADDRESS and press "Enter" you see the screen on the right. The panel must have an IP address that is compatible with the network that it will be connected to. Consult your network administrator for the IP address. In order to program the address, use the arrow keys. The up/down keys are used to increase the value and the right/left keys are used to select the digit. Once the IP address is set press "Enter". By default the IP address is 10.0.1.143.

IP ADDRESS	
010.020.030.001	
^	

If any adjustments are made (like setting a new IP address) on the Ethernet module, please select the option RESET ETHERNET and press "Enter". This procedure initializes the connection so the panel is able to connect with the new IP address.

RESET ETHERNET PLEASE WAIT	
-------------------------------	--

## 4.2 Programming via PC

No special software is needed to program the system from a PC. A common browser such as Google Chrome, Mozilla Firefox, Internet Explorer, etc can be used. The following photos show the use of Google Chrome. **We recommend using Google Chrome web browser.**

The requirements needed are a common network with a PC and a CBS system connected to it. You also need to know the IP address of the CBS system in order to operate it remotely. There is the option to have access to the system via internet globally, if the correct adjustments on the network are made by the network administrator of the building.

The first action is to open a web browser and then enter the IP address of the panel in the URL area. If everything is connected correctly then you will see the following page.

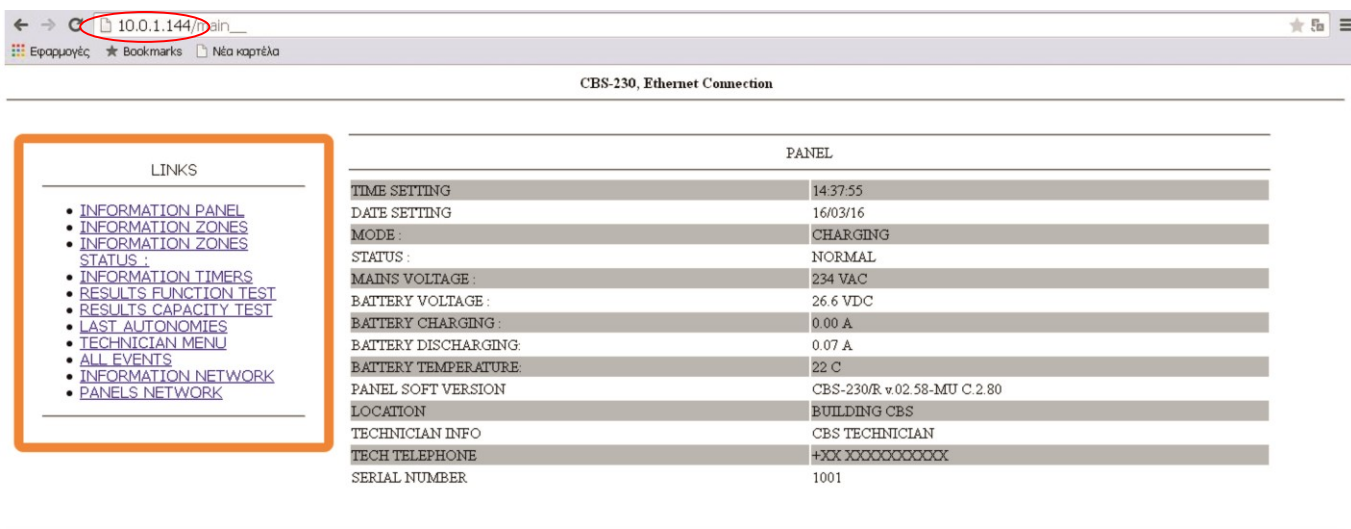

By clicking on the link **TECHNICIAN MENU** you see the following page

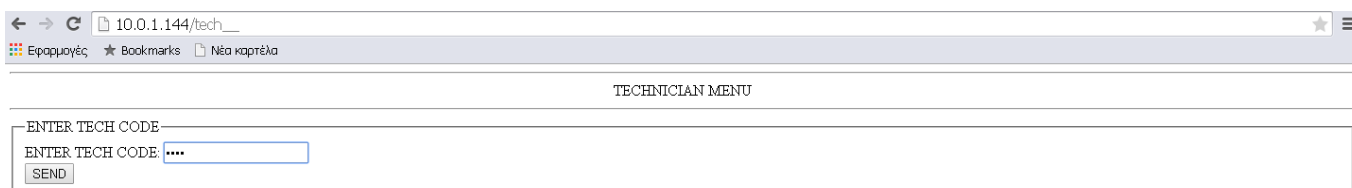

Place the cursor on the **TECH CODE** field, enter the tech code and press **SEND**. If the code is correct then the following page appears. If not, then a “wrong code” message is displayed.

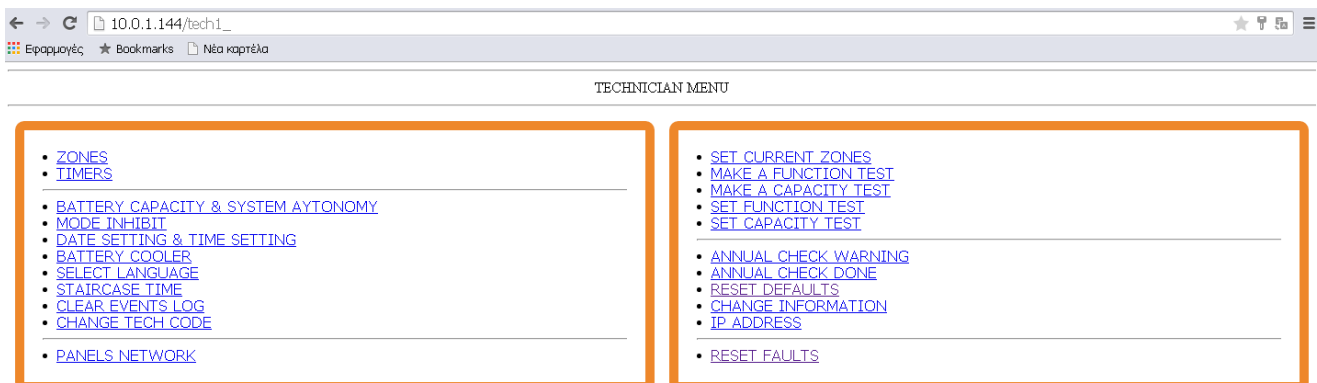

### 4.2.1 Programming the zones

Click on the first link ZONES and then the following page appears. In this page you can set all the available options for each zone.

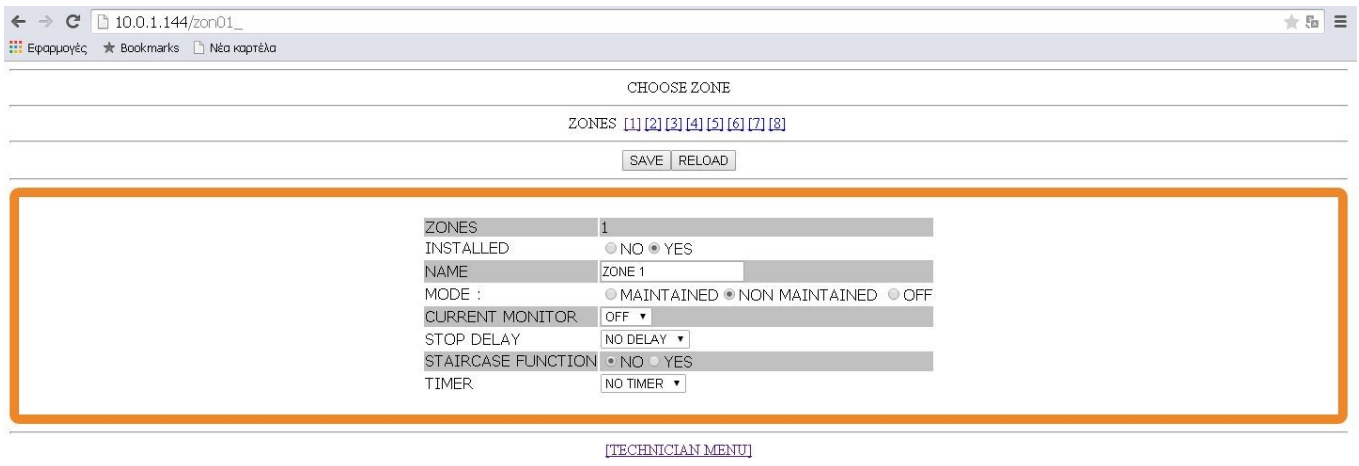

First click on the zone that you want to program. Then select if it is installed, modify the name of the zone (if needed), select its mode of operation. For current monitoring you can select an option from the drop down list. You can also choose a different stop delay from the drop down list below.

If the zone has been set as MAINTAINED then the option STAIRCASE FUNCTION is active but does not affect the operation of the zone. In the TIMER field you can select a timer for this zone. The timers are used to turn OFF the lights automatically on zones that have been programmed as MAINTAINED when there are no people in the building. This way you can conserve energy without degrading the safety level of the building. Even if a zone have been turned OFF by a timer, in an event of a power failure the luminaires connected to this zones will be turned ON.

If a zone has been set to operate as NON-MAINTAINED the selection TIMER is active but does not affect the operation of the zone.

When done press the SAVE button on top to keep the adjustments into the memory. You can adjust all zones by selecting a zone and repeating the procedure.

Clicking on TECHNICIAN MENU link goes back to the technician menu page.

### 4.2.2 Programming timers

By selecting in the technicians menu the TIMERS option you see the page below.

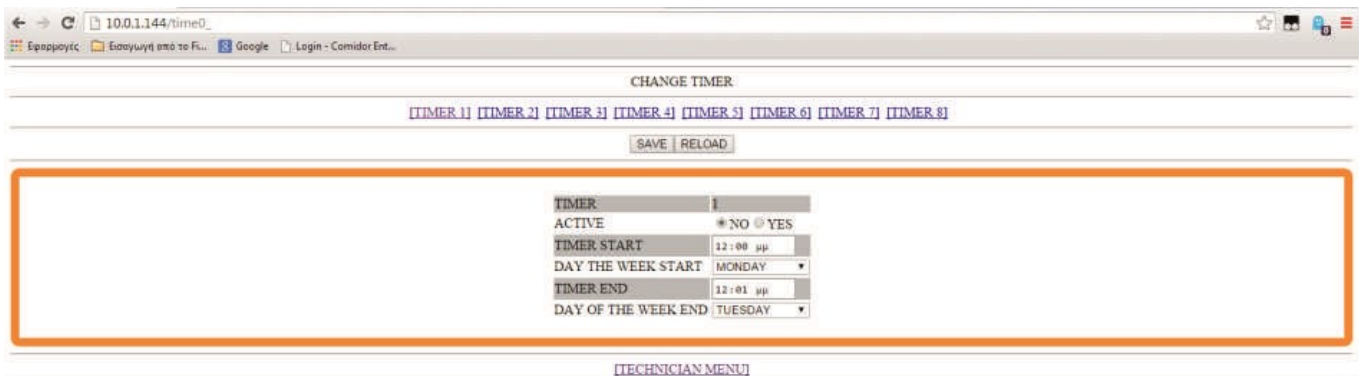

In this screen you can program the timers. Click on the desired timer and YES to activate. Adjust the start time and day and the end time and day. The option DAY OF THE WEEK START has the options DAILY, WEEKDAY and WEEKEND. With the selection DAILY the timer is repeated daily. With the option WEEKDAY the timer is repeated from Monday to Friday and during the weekend it is off. With the option WEEKEND the timer will be repeated only on weekend. If you select one of these options it does not matter what end date you select.

Click the SAVE button to keep the settings on the system memory.

  <p><i>for a safer world!</i></p>	Date	9/5/2022
	Document	923950003_09_010
	Document code	923950003_09_010
	Page	23 from 39

By clicking TECHNICIAN MENU you can go back to the technician menu page.

### 4.2.3 Programming the battery capacity and the autonomy

Clicking on the BATTERY CAPACITY & SYSTEM AUTONOMY you can see the following image



Use the keyboard to write the battery capacity (33 or 55Ah). In the option SYSTEM AUTONOMY select one of the following durations (1HOUR, 1.5 HOUR, 2 HOURS, 3 HOURS or 8 HOURS).

*The system autonomy when the maximum load is installed, is 1 hour. For more duration the luminaire load must be calculated accordingly.*

Press the SAVE button to keep the settings in the system memory.

Clicking on TECHNICIAN MENU goes back to the technician menu page.

### 4.2.4 INHIBIT function

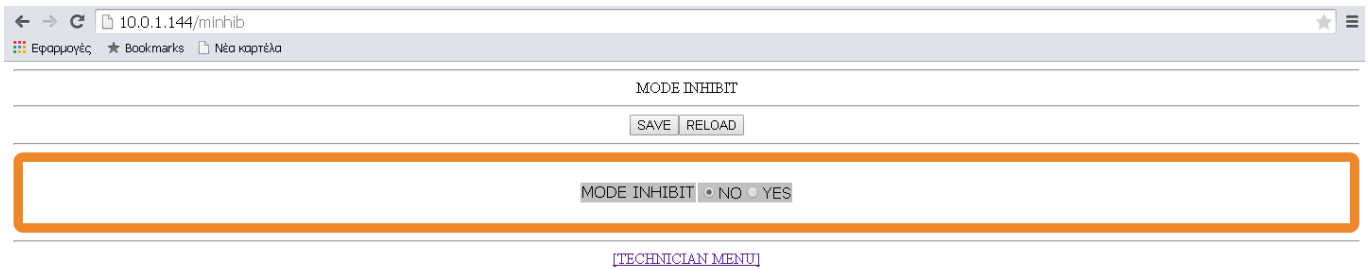

By default this option is set to OFF. If you select YES and press SAVE the system automatically enters a state where it only charges the batteries. Maintained-mode zones will keep lighting when the mains power is on but in case of a power failure all zones will be inactive and will not light. INHIBIT function is used when a building is not in use and without occupants for a large time period.

If you select NO and press SAVE, the panel enters the normal operation state.

Clicking on TECHNICIAN MENU goes back to the technician menu page.

### 4.2.5 Adjusting the date and time

By clicking DATE SETTING & TIME SETTING you enter to the following page.

  <p>for a safer world!</p>	Date	9/5/2022
	Document	923950003_09_010
	Document code	923950003_09_010
	Page	24 from 39

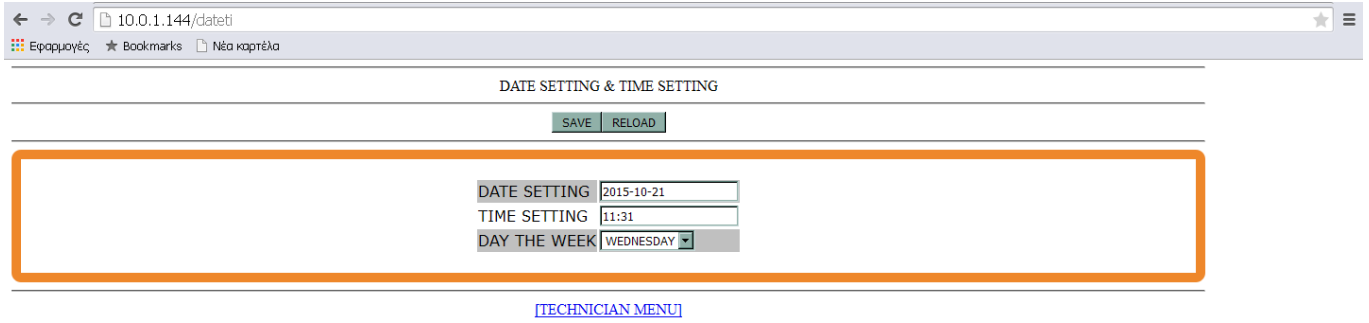

Adjust the date, time and day of the week and press SAVE. These setting must be done during the initial system setup so as to have an accurate log of the events.

*Note that the date format is year/month/date.*

Clicking on TECHNICIAN MENU goes back to the technician menu page.

#### 4.2.6 Battery cooler

Clicking on BATTERY COOLER goes in the following page.

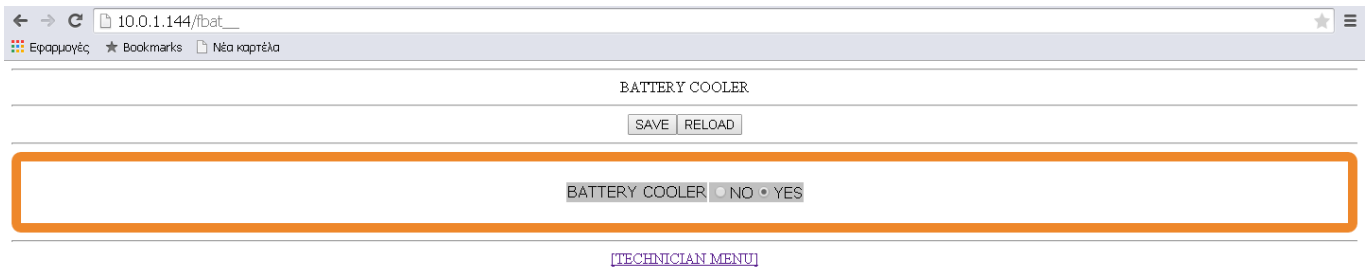

By default this option is set to NO. If a battery cooler has been installed in the batteries' compartment then in order for it to operate you must select YES and press SAVE.

Clicking on TECHNICIAN MENU goes back to the technician menu page.

#### 4.2.7 Change Language

Clicking on SELECT LANGUAGE goes in the following page.

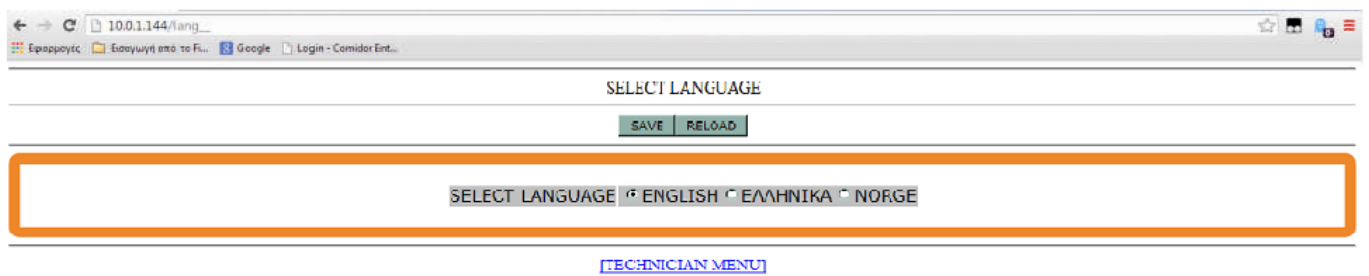

Select GREEK, ENGLISH or NORGE and press SAVE. The language selection affects the language of the panel, the language of the PC software and the logged events. All previously logged events will be displayed in the current language.

#### 4.2.8 Staircase time

Click on STAIRCASE TIME to adjust it in the following page.

  <p>olympia™ electronics</p> <p>SAFETY &amp; SECURITY SYSTEMS</p> <p><i>for a safer world!</i></p>	Date	9/5/2022
	Document	923950003_09_010
	Document code	923950003_09_010
	Page	25 from 39

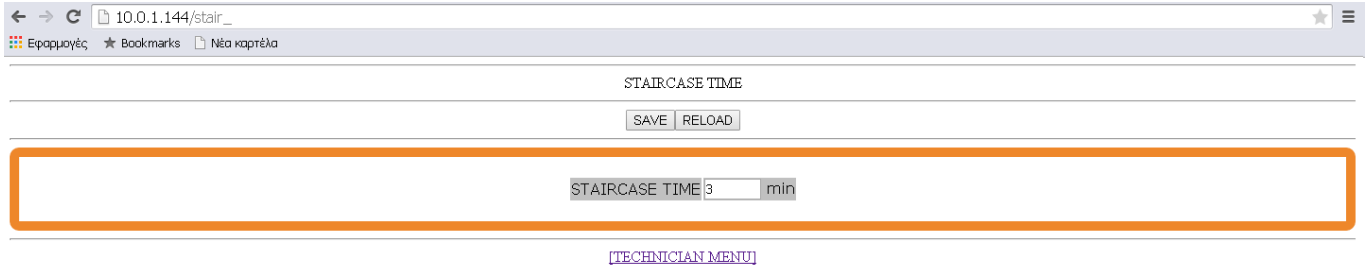

Type the time that the staircase luminaries will be ON and press SAVE. By default the time is 3 minutes. Clicking on TECHNICIAN MENU goes back to the technician menu page.

#### 4.2.9 Clearing the events log

Click on CLEAR EVENTS LOG to clear all logged events in the following page.



In this page you see the confirmation screen. If you press YES then all the events will be wiped from the memory and you will be redirected to the previous page.

Clicking on TECHNICIAN MENU goes back to the technician menu page.

#### 4.2.10 Changing the tech code

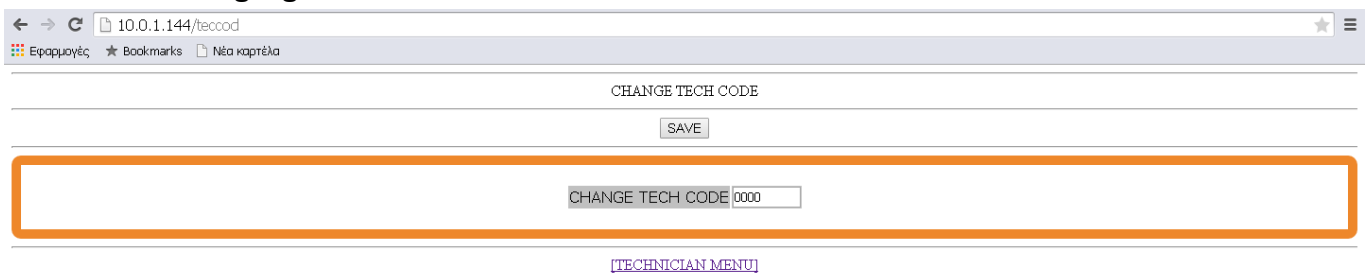

By clicking on CHANGE TECH CODE you can change the technician code. Before changing this code mind that once changed, there is no way to reset the code to the previous one if you don't have the new one, so it has to be responsibly done. Enter a new 4-digit code and press SAVE.

Clicking on TECHNICIAN MENU goes back to the technician menu page.

### 4.2.11 Network of panels

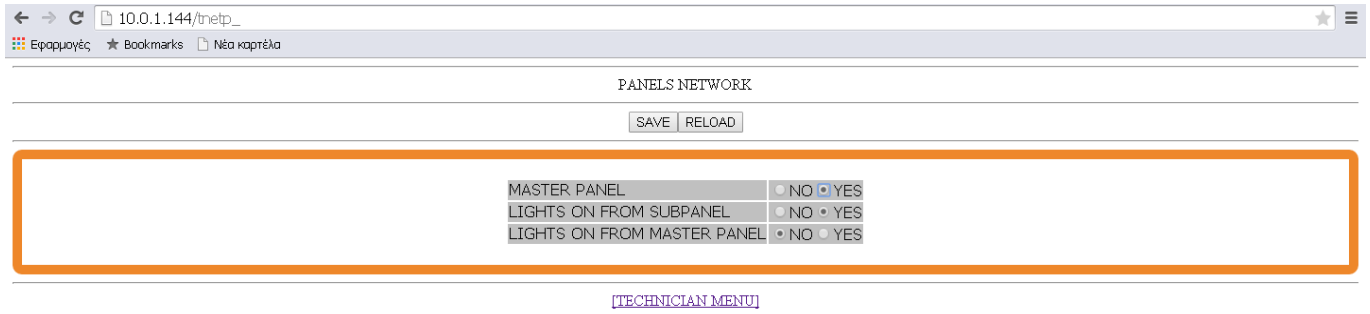

With the option PANELS NETWORK combined with the SUBPANELS SETUP you can adjust the network if more than one panel are required in the same building to operate in cooperation with each other.

First select if the panel is the Master (select YES) or a subpanel (select NO).

In the option LIGHTS ON FROM SUBPANEL, if you select NO then the specific panel (either master or subpanel) will not enter emergency operation if another subpanel has entered it. If you select YES then the specific panel will enter emergency operation when any other subpanel enters it.

The option LIGHTS ON FROM MASTER PANEL matters only if you are programming a subpanel. If you select NO the specific subpanel will not enter emergency operation when the master panel enters it. Selecting YES it will enter emergency operation when the master panel enters it.

### 4.2.12 Subpanel Setup

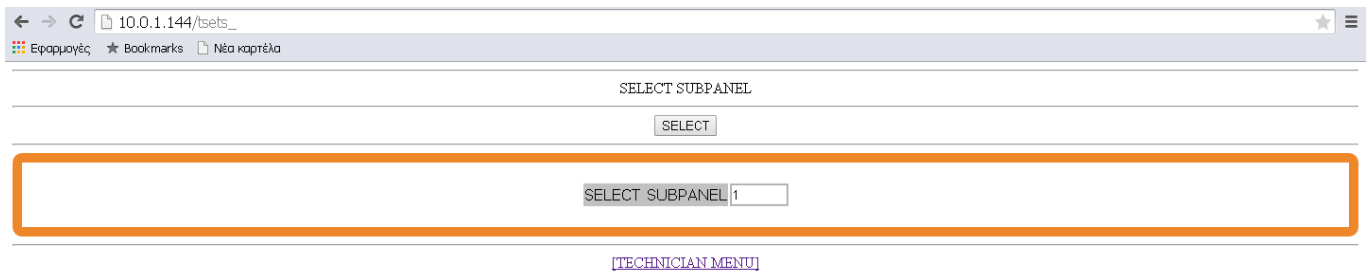

If you set the current panel as Master then via this page (SUBPANEL SETUP) you can program its subpanels. Enter the panel number (starting from 1) and press SELECT. You see the following image.

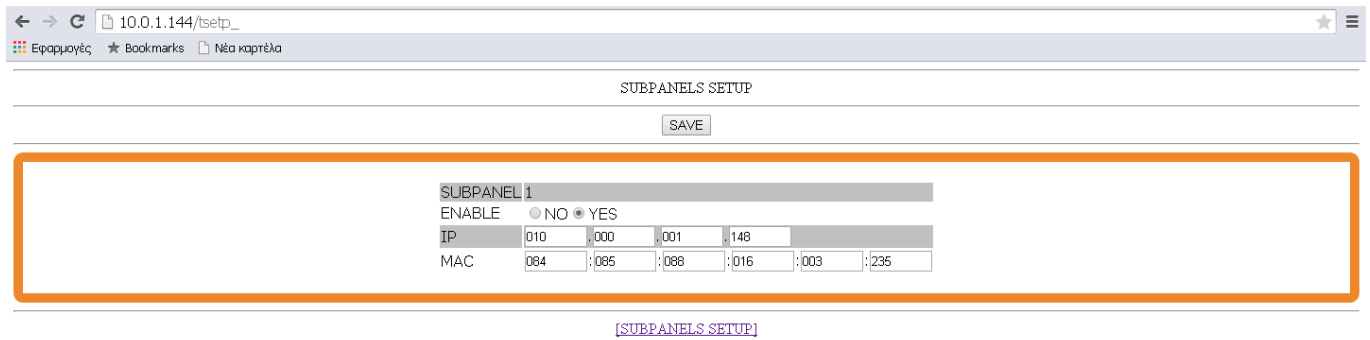

Set the ENABLE option to YES and enter the IP and MAC address of the subpanel in position 1.

These addresses can be found in the option INFORMATION NETWORK in the initial menu of the subpanel (via Ethernet).

Select SAVE and continue with all consecutive subpanels.

  <p>olympia™ electronics</p> <p>SAFETY &amp; SECURITY SYSTEMS</p> <p><i>for a safer world!</i></p>	Date	9/5/2022
	Document	923950003_09_010
	Document code	923950003_09_010
	Page	27 from 39

### 4.2.13 Set the current of the zones

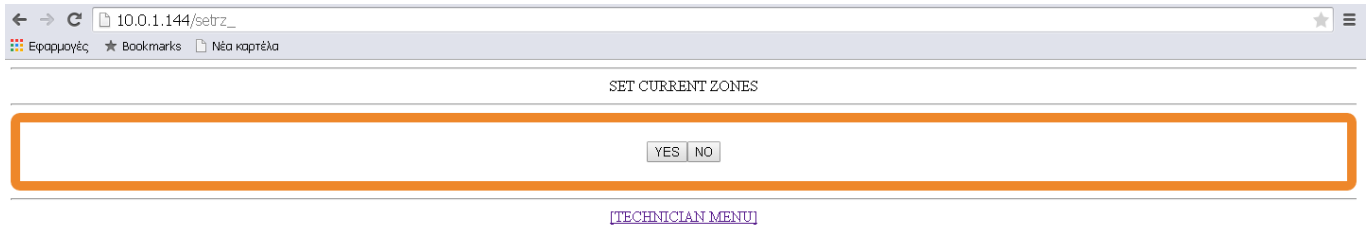

By clicking on the option SET CURRENT ZONES in the tech menu you can see the above confirmation page. If you press YES, the panel erases from the memory all previous current entries and executes the operation CURRENT ADJUST. The adjustment of the current must be done when the installation has finished and when all luminaires have been verified that operate correctly. It must also be done every time a luminaire is added or removed. The procedure lasts 90 seconds and when it finishes, the current that the total load draws, is saved in the system memory. This entry will be used in every function test to determine if all values match to the previous. If not, there is a probability that some luminaires are not operating correctly.

*Note: Before starting this operation be sure that the batteries of the panel are charged to at least 60% of the capacity.*

Clicking on TECHNICIAN MENU goes back to the technician menu page.

### 4.2.14 Function test

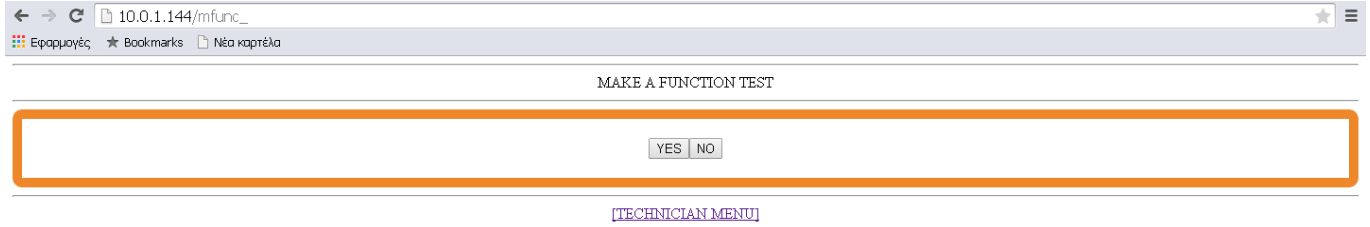

By pressing YES a complete function test is conducted.

Clicking on TECHNICIAN MENU goes back to the technician menu page.

### 4.2.15 Capacity test

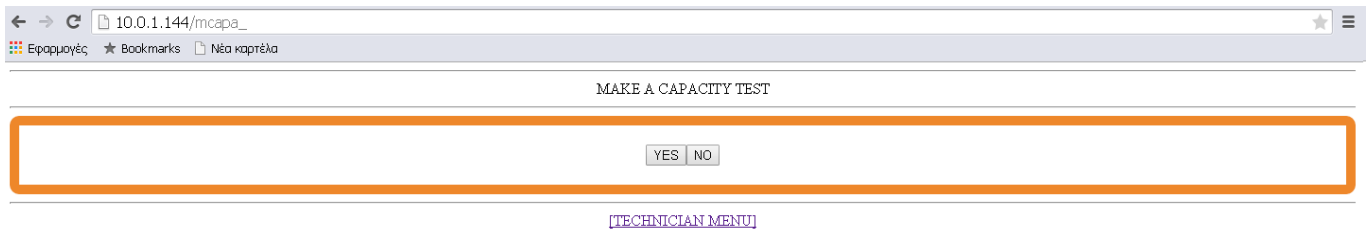

By pressing YES a complete capacity test is conducted.

Clicking on TECHNICIAN MENU goes back to the technician menu page.

#### 4.2.16 Programming the function test

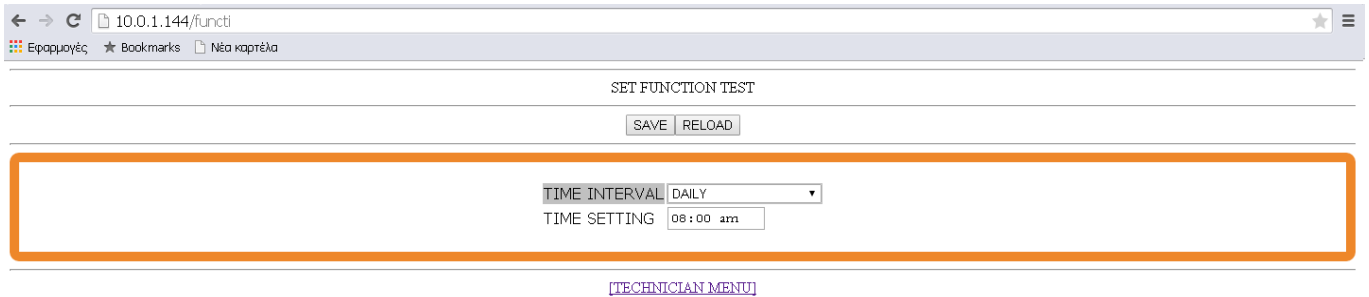

Via this page you can program the automatic function test. In the selection TIME INTERVAL select DAILY, EVERY OTHER DAY or one of the days of the week. Enter the time in the TIME SETTING box and press SAVE.

Clicking on TECHNICIAN MENU goes back to the technician menu page.

#### 4.2.17 Programming the capacity test

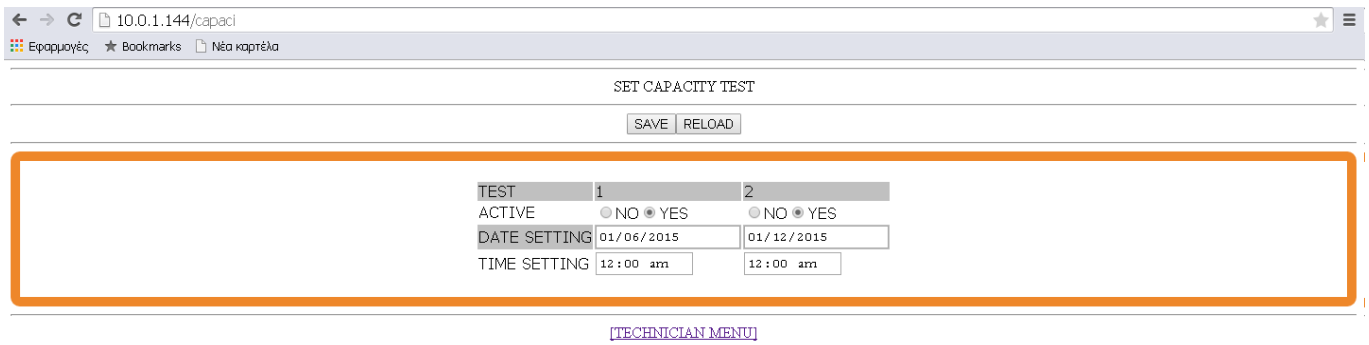

Via this page you can program the next 2 consecutive capacity tests. By default both tests are active. To program the capacity test select YES in the selection ACTIVE for test 1 and test 2 (if needed). Adjust the time and date for each test and press SAVE.

With the capacity test the system tests the batteries' capability of sustaining the stated autonomy. The capacity test must be done from once every 6 months to once a year. The duration of the test is 2/3 of the stated autonomous duration of the panel.

Clicking on TECHNICIAN MENU goes back to the technician menu page.

#### 4.2.18 Programming the annual check warning

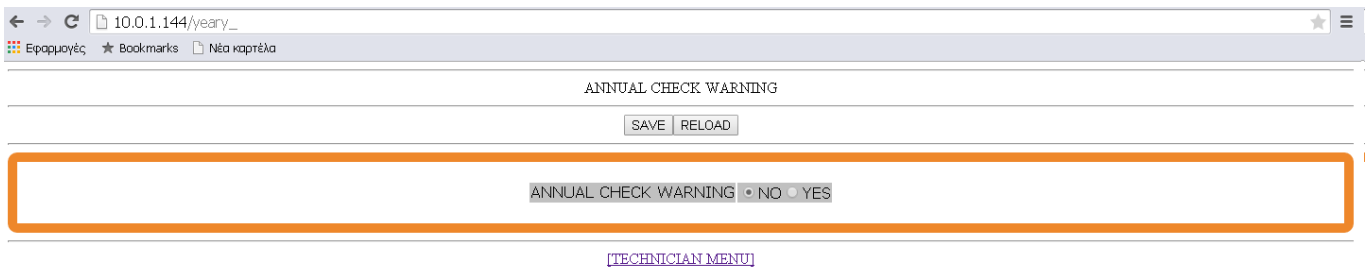

By selecting YES and pressing SAVE you will receive a reminding message on the panel's screen or on the PC interface (panel's ethernet page) yearly.

Clicking on TECHNICIAN MENU goes back to the technician menu page.

  <p>for a safer world!</p>	Date	9/5/2022
	Document	923950003_09_010
	Document code	923950003_09_010
	Page	29 from 39

### 4.2.19 Annual Test OK

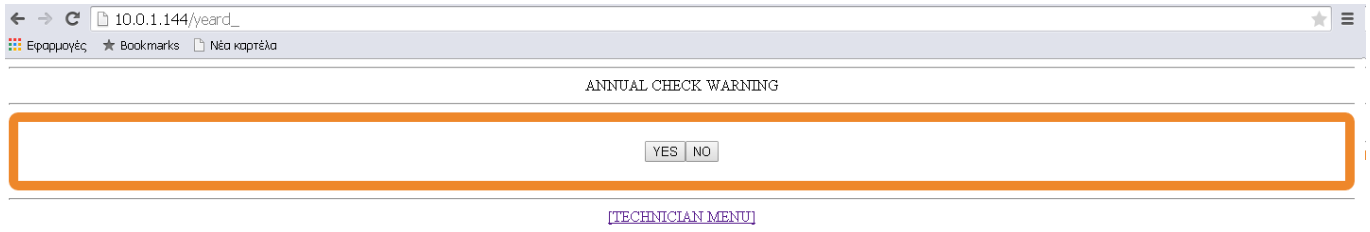

Via this page you can delete the reminding message for the required annual tests if they have been conducted. By pressing YES the message is deleted.

Clicking on TECHNICIAN MENU goes back to the technician menu page.

### 4.2.20 Setting Defaults

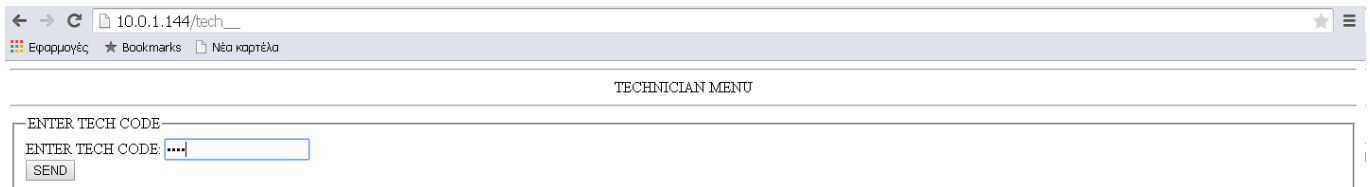

With this selection you can restore the panel to its factory default settings. For confirmation the panel asks for the technician code. After the end of the procedure the main menu is shown.

### 4.2.21 Changing information

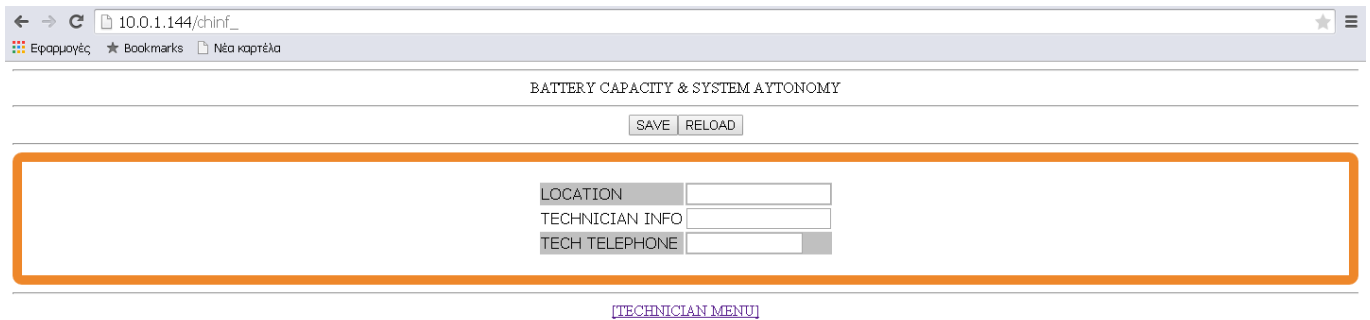

Via this page you can change the general information of the panel. You can change the LOCATION (up to 24 characters), the TECHNICIAN INFO (up to 24 characters) and the TECH TELEPHONE (up to 16 characters).

By pressing SAVE all the information is stored in the system's memory.

Clicking on TECHNICIAN MENU goes back to the technician menu page.

  <p>for a safer world!</p>	Date	9/5/2022
	Document	923950003_09_010
	Document code	923950003_09_010
	Page	30 from 39

#### 4.2.22 IP address

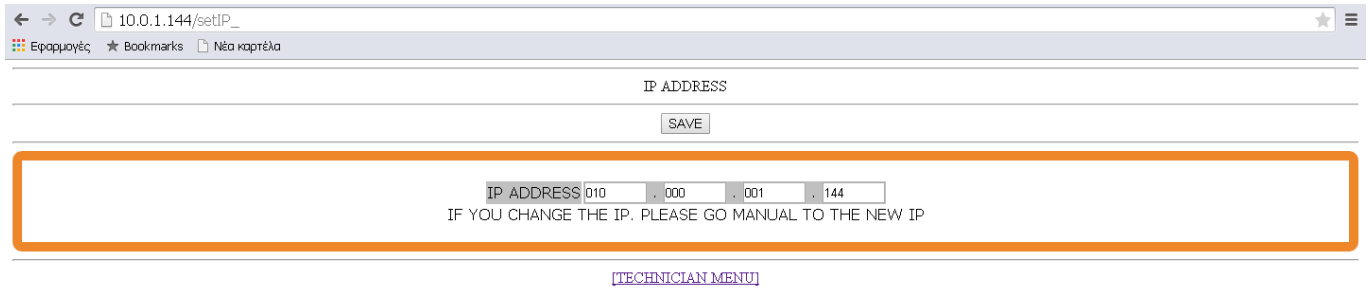

Via this screen you can change the IP address of the panel.

Press SAVE to keep the new IP address in the system's memory. After saving, the communication between the panel and the PC web browser will terminate. Then you must manually enter the new IP address in the URL bar of the browser. (see par. 4.2).

#### 4.2.23 Resetting faults

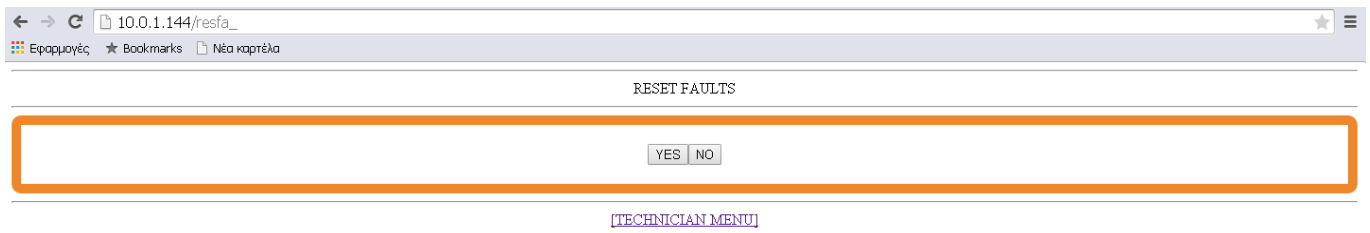

In this page if you press YES then all the current panel faults are cleared.

Clicking on TECHNICIAN MENU goes back to the technician menu page.

## 5. Use

The GR-9500 central emergency lighting system is made to operate without the continuous supervision from the user. The function test as well as the autonomous durations test can be programmed to be executed automatically. The building attendant can see the results at any time. If no errors are logged then he does not have to take any actions. If any error is observed then he can fix it or he can consult an electrician, depending on the cause. The user has a variety of options to manually inspect the whole system whenever required.

When the panel is in normal operation the screen on the right is shown. Also the indicators POWER, CHARGE and zones' POWER are lit. (see par. 3).

```

MODE :
      CHARGING
-----
STATUS : NORMAL
-----
BATTERY :27.6V - 0.1A
      14:25   MO 24/02/14
  
```

If for any reason you do not want the panel to enter emergency operation (e.i. during closed periods of hotels), press the INHIBIT key. The indicator INHIBIT is lit and the screen should look like the image on the right. To exit INHIBIT mode simply press again the INHIBIT key.

```

MODE :
      CHARGING
      INHIBIT
-----
STATUS : NORMAL
-----
BATTERY :27.6V - 0.1A
      14:25   MO 24/02/14
  
```

### 5.1 Operation using the keypad

#### 5.1.1 Test

By pressing the "Enter" key you enter the user MENU as shown in the screen on the right. If there was a previous test conducted and there were faults then the first option would be CURRENT FAULTS. All the options except the TECHNICIAN MENU are available to the user. For tech menu entry the technician code is needed and should be accessed only by authorized personnel.

```

      MENU
-----
TEST
INFORMATION
TECHNICIAN MENU
RESET
ALL EVENTS
TEST EARTH FAULT
  
```

If there is a CURRENT FAULTS option and you press "Enter" you can see the screen on the right. If you select RESET FAULTS and press "Enter" the panel resets all the current faults (and logs them into the memory).

```

      CURRENT FAULTS
-----
SHOW FAULTS
RESET FAULTS
  
```

If you select SHOW FAULTS and press "Enter" you can see a screen as in the image on the right. When an error is displayed there is always an "X" on the top left corner that blinks. To the right with bold characters you can see the source of the fault (In our case Zone 4). Under the blinking "X" you can see the name of the zone (underground) followed by a detailed description. On the last line you can see the number of the fault to the total faults. With the up/down arrow keys you can navigate through the faults. With the "Esc" key you go to the previous menu.

```

  X      FAULT
      ZONE 04
UNDERGROUND
OVERCURRENT FAULT
23/01/14   15:31
111/112
  
```



*for a safer world!*

Date	9/5/2022
Document	923950003_09_010
Document code	923950003_09_010
Page	32 from 39

If you select TEST and press "Enter" you will see the screen on the right.

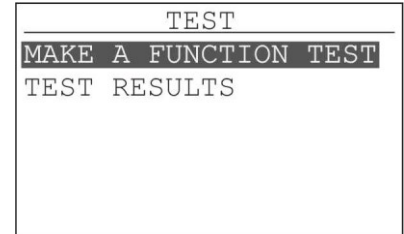

If you select MAKE A FUNCTION TEST and press "Enter" a manual function test is conducted. Its duration is 90 seconds. The screen shows the remaining time, the battery voltage and the discharging current that the whole load consumes from the batteries.

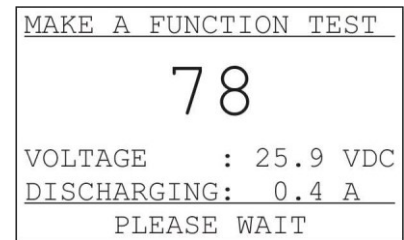

When the test finishes the screen on the right is shown. The first line shows the date and the hour of the test. The following 3 lines show the faults that have been detected for the system, the zones and the battery. By pressing "Esc" you return to the previous menu. If faults have been detected then you must go to the menu CURRENT FAULTS for more details.

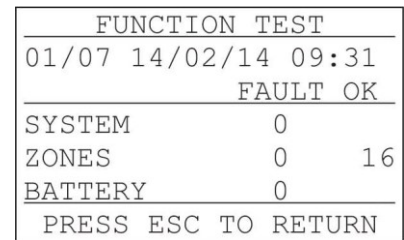

If you select TEST RESULTS and press "Enter" you can see the screen on the right.

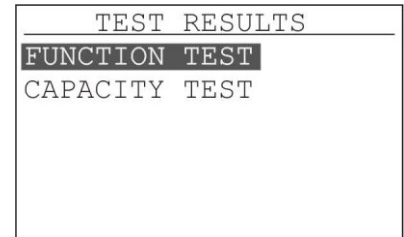

If you select FUNCTION TEST and press "Enter" you see the screen on the right. The first line shows the indication 01/XX (where XX the amount of tests in memory) as well as the date and hour of the test. The following 3 lines show the faults detected on the system zones and battery. The last line shows the battery voltage and current at the end of the test. If more than 1 test are in memory then using the up/down arrow keys you can view them all.

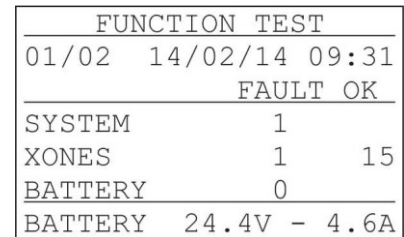

If you select CAPACITY TEST and press "Enter" you see the screen on the right. The first line shows the indication 01/XX (where XX the amount of tests in memory) as well as the date and hour of the test. The following 3 lines show the results of the test (Passed or Failed), the duration and the capacity of the batteries. The last line shows the battery voltage and current at the end of the test. If more than 1 test are in memory then using the up/down arrow keys you can view them all.

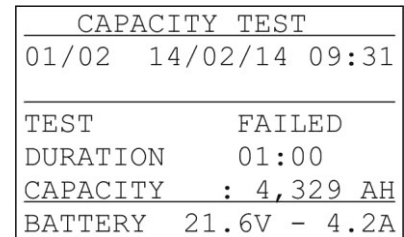

During the first three months after the installation probably there will be no data concerning the autonomous duration.

If no information is available then the screen on the right is shown.

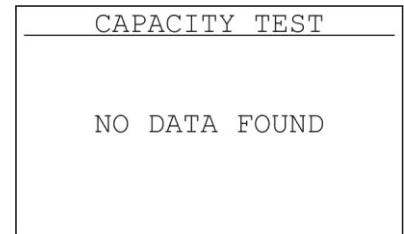



for a safer world!

Date	9/5/2022
Document	923950003_09_010
Document code	923950003_09_010
Page	33 from 39

### 5.1.2 Information

By selecting INFORMATION and pressing “Enter” you see the screen on the right. The INFORMATION menu contains additional options that are not visible on the first screen. Using the up/down keys you can navigate to these options. These are COMMUNICATION CHAR., PANEL SOFT VERSION and TECHNICIAN INFO.

INFORMATIONS	
<b>BATTERY</b>	▲
MAINS	█
ZONES	
PANEL	
NETWORK	
LAST AUTONOMIES	▼

The battery information shows the battery voltage, charge/discharge current and the temperature of the batteries’ compartment.

BATTERY	
VOLTAGE	: 27.5 VDC
CHARGING	: 0.45 A
TEMPERATURE:	23 C
PRESS ESC TO RETURN	

The mains power information shows the current voltage of the mains power supply.

MAINS	
VOLTAGE	: 230 VAC
PRESS ESC TO RETURN	

If you select ZONES and press “Enter” then you see the screen on the right. Use the up/down arrow keys to select the required zone and press “Enter”.

CHOOSE ZONE		
CHOOSE FROM 1 TO 8		
	<input type="text" value="1"/>	

The screen shows information of the selected zone. You can see if it is installed, the zone’s output current, if the fuse is OK (NORMAL or FAULT), the current status (AC, AC INVER or OFF) and the voltage state of the output (NORMAL or FAULT). By pressing “Esc” you return to the INFORMATION menu.

ZONE 1	
INSTALLED	YES
CURRENT	: 0.000 A
FUSE STATUS	NORMAL
STATUS	: OFF
VOLTAGE	: NORMAL
PRESS ESC TO RETURN	

If you select PANEL and press “Enter” you can see the screen on the right. The CUREERENT LIMIT shows the total current that is drawn from the batteries. You can also see if the battery fan is operating (ON or OFF) and finally the STATUS which is OK if no fault is detected and FAULT if an error is detected (on the battery fan). By pressing “Esc” you return to the INFORMATION menu.

PANEL	
CURRENT LIMIT	2.5A
BATTERY COOLER	
MODE :	OFF
STATUS :	OK
PRESS ESC TO RETURN	

If you select NETWORK and press “Enter” you can see the screen on the right. In this screen you can see if the Ethernet card is installed and also the IP and MAC address of the system. By pressing “Esc” you return to the INFORMATION menu.

NETWORK	
ETHERNET PCB	YES
IP =	010.020.030.040
MAC	54:55:58:10:03:EF
PRESS ESC TO RETURN	

With the option LAST AUTONOMIES you can see all the logged autonomy durations of the system. On the first line you can see 01/XX (where XX the number of logged duration tests) along with the date and time of each logged event. You can see if the panel is fully charged or not, the duration of the emergency operation and the battery capacity used. With the up/down arrow keys you can change the logged emergency states. By pressing “Esc” you go back to the INFORMATION menu.

LAST AUTONOMIES	
01/02	18/02/14 10:52
CHARGING	FULL
DURATION	1MIN
CAPACITY	: 0.035 AH
PRESS ESC TO RETURN	

With the option PANEL SOFT VERSION you can retrieve information regarding the firmware installed in the panel. By pressing “Esc” you go back to the INFORMATION menu.

By selecting TECHNICIAN INFO and pressing “Enter” you see information regarding the name of the technician the telephone number and a general description of the panel. This information can be changed only by using a PC (via Ethernet). Press “Esc” to return to the INFORMATION menu.

### 5.1.3 Reset

By selecting RESET and pressing “Enter” the system resets all faults, including the message “CUTOFF TOOK PLACE”.

*The message “CUTOFF TOOK PLACE” is displayed when system restores from a previous Battery Cut-Off, due to low battery voltage when in emergency.*

### 5.1.4 All Events

By selecting the option ALL EVENTS in the main menu and pressing “Enter” you can see the screen on the right. The top screen shows the logged information and the bottom screen shows the logged faults.

<b>i</b>	GENERAL PANEL
EXIT TECH MENU	
24/02/14 14:51	
112/112	

On logs containing information you can see the symbol **i** on the top left. On its right with bold characters you can see the source of the event (in this case GENERAL PANEL). Below this you can see a description of the event, the date and time. The last line shows the number of the event to the total number of logged events.

On logs containing faults you can see the symbol X on the top left. On its right with bold characters you can see the source of the fault (in this case the ZONE 04). Under the X you can see the name of the zone (UNDERGROUND). Below this you see a description of the fault, the date and time. The last line shows the number of the fault to the total number of logged events.

<b>X</b>	FAULT ZONE 04
UNDERGROUND	
OVERCURRENT FAULT	
23/01/14 15:31	
111/112	

With the up/down arrow keys you navigate between events. Press “Esc” to return to the previous menu.

### 5.1.5 Earth Test

If you select TEST EARTH FAULT and press “Enter” you deliberately invoke an earth fault to determine if the circuit that detects earth fault and the indicators are operating. After the test finishes the system returns to the initial screen. Please be informed that when the batteries are disconnected and the battery fuse is unplugged, the earth fault will not appear.

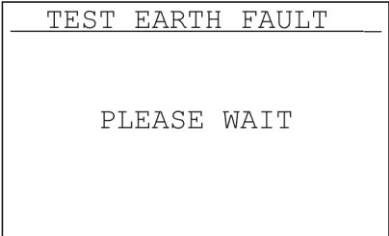

### 5.1.6 LED test

If you select TEST LED and press “Enter” you see the screen on the right. All LEDs on the front face are lit so you can inspect them visually. Press “Esc” to return to the initial screen.

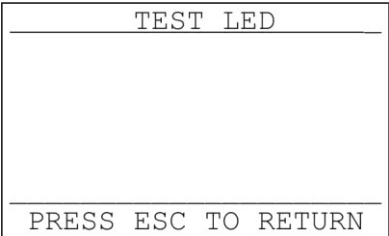

## 5.2 Operation via PC

The text below describes how a user can retrieve information of the system via a PC. The access for a common user is not full, because there are no options to program the system. For system programming via a PC see par. 4.2.

No special software is needed to use the system via a PC. A common web browser such as Google Chrome, Mozilla Firefox, Internet Explorer, etc can be used. The following photos show the use of Google Chrome. The requirements are that the panel must have an Ethernet card installed, you have to know its IP address, the computer must be connected to the same network and the settings must be correct. With suitable settings you can have access to the panel via internet globally. All these setting must be adjusted from the network administrator of the building.

The first action is to open a web browser and for the URL you must enter the IP address of the panel. If everything is connected correctly then you will see the following screen.

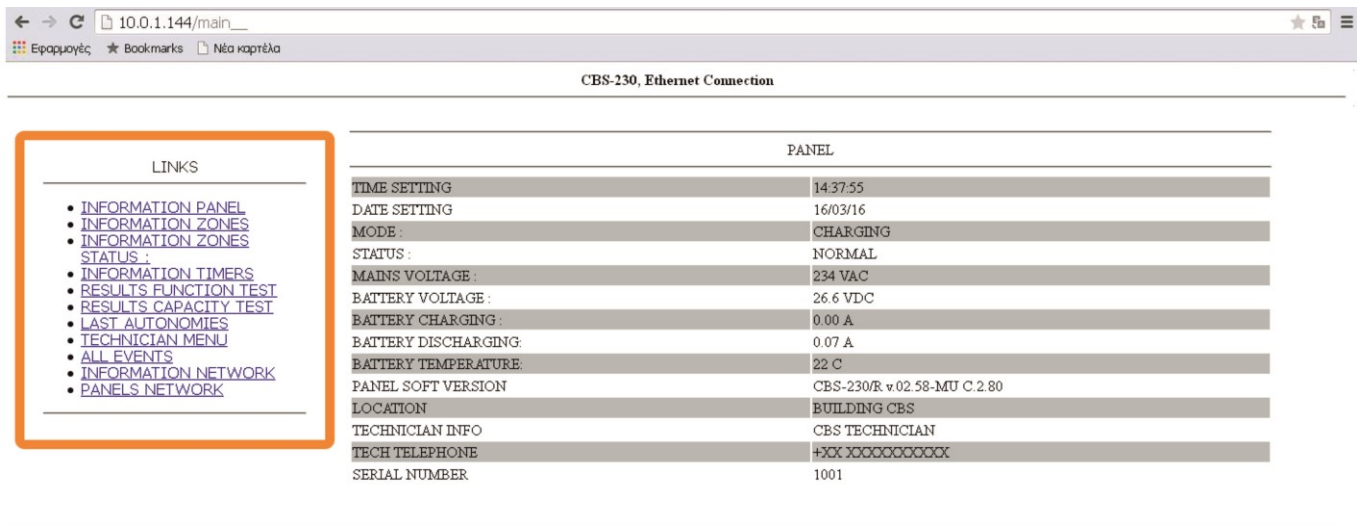

All options available to the user are shown in the LINKS on the left apart from the TECHNICIAN MENU.

### 5.2.1 Panel Information

By selecting INFORMATION PANEL you see the following screen which shows the current state of the panel.



for a safer world!

Date	9/5/2022
Document	923950003_09_010
Document code	923950003_09_010
Page	36 from 39

10.0.1.144/pane\_

ΕΡΕΜΠΟΛΟΓΟΣ ΕΙΣΑΓΩΓΗ ΑΠΟ ΤΟ F... Google Login - Corridor Ent...

PANEL

TIME SETTING	14:49:18
DATE SETTING	16/03/16
BATTERY CAPACITY	55 Ah
SYSTEM AUTONOMY	1 HOUR
MAINS VOLTAGE :	236 VAC
BATTERY VOLTAGE :	26.5 VDC
BATTERY CHARGING :	0.00 A
BATTERY DISCHARGING :	0.07 A
BATTERY TEMPERATURE :	22 C
BATTERY CURRENT LIMIT :	0.7 A
CONS. FROM BAT :	0 W
CONS. FROM MAINS :	0 VA
BATTERY COOLER MODE :	OFF
BATTERY COOLER STATUS :	OK
PANEL SOFT VERSION :	CBS-230/R v.02.58-MU C.2.80
LOCATION :	BUILDING CBS
TECHNICIAN INFO :	CBS TECHNICIAN
TECH TELEPHONE :	+XX XXXXXXXXXXX
SERIAL NUMBER :	1001

[\[MAIN PAGE\]](#)

### 5.2.2 Zone programming information

In this screen you can see how each zone has been programmed to operate. The current limit column displays the current that has been measured during the CURRENT MEASUREMENT in the initial installation.

10.0.1.144/info\_

ΕΡΕΜΠΟΛΟΓΟΣ ΕΙΣΑΓΩΓΗ ΑΠΟ ΤΟ F... Google Login - Corridor Ent...

ZONES

ZONES	INSTALLED	NAME	MODE	CURRENT MONITOR	CURRENT LIMIT	STOP DELAY	STAIRCASE FUNCTION	TIMER
1	YES	ZONE 1	NON MAINTAINED	OFF	0.00 ADC	10 SECONDS	YES	NO TIMER
2	YES	ZONE 2	NON MAINTAINED	OFF	0.00 ADC	10 SECONDS	NO	NO TIMER
3	YES	ZONE 3	NON MAINTAINED	OFF	0.00 ADC	10 SECONDS	NO	NO TIMER
4	YES	ZONE 4	NON MAINTAINED	OFF	0.00 ADC	10 SECONDS	NO	NO TIMER

### 5.2.3 Zones status information

10.0.1.144/info\_

ΕΡΕΜΠΟΛΟΓΟΣ ΕΙΣΑΓΩΓΗ ΑΠΟ ΤΟ F... Google Login - Corridor Ent...

ZONES

ZONES	INSTALLED	SUPPLY	CURRENT	FAULT	FUSE STATUS	VOLTAGE
1	YES	OFF	-		OK	OK
2	YES	OFF	-		OK	OK
3	YES	OFF	-		OK	OK
4	YES	OFF	-		OK	OK

### 5.2.4 Timer information

10.0.1.144/info\_

ΕΡΕΜΠΟΛΟΓΟΣ ΕΙΣΑΓΩΓΗ ΑΠΟ ΤΟ F... Google Login - Corridor Ent...

TIMERS

TIMERS	ACTIVE	TIMER START	DAY THE WEEK START	TIMER END	DAY OF THE WEEK END
1	NO	12:00	MONDAY	12:01	TUESDAY
2	NO	12:00	MONDAY	12:01	TUESDAY
3	NO	12:00	MONDAY	12:01	TUESDAY
4	NO	12:00	MONDAY	12:01	TUESDAY
5	NO	12:00	MONDAY	12:01	TUESDAY
6	NO	12:00	MONDAY	12:01	TUESDAY
7	NO	12:00	MONDAY	12:01	TUESDAY
8	NO	12:00	MONDAY	12:01	TUESDAY

[\[MAIN PAGE\]](#)

You can see the programming of the timers.



for a safer world!

Date	9/5/2022
Document	923950003_09_010
Document code	923950003_09_010
Page	37 from 39

## 5.2.5 Function test results

RESULTS FUNCTION TEST

FUNCTION TEST	DATE SETTING	SYSTEM FAULT	ZONES OK	ZONES FAULT	BATTERY FAULT	BATTERY VOLTAGE :	BATTERY DISCHARGING:
1	28/10/14 08.01	0	16	0	0	26.1V	0.4A
2	29/10/14 08.01	0	16	0	0	25.9V	0.4A
3	30/10/14 08.01	0	16	0	0	26.1V	0.4A
4	30/10/14 11.52	0	16	0	0	26.3V	0.4A
5	31/10/14 08.01	0	16	0	0	26.1V	0.4A
6	01/11/14 08.01	0	16	0	0	26.4V	0.4A
7	02/11/14 08.01	0	16	0	0	26.4V	0.4A
8	03/11/14 08.01	0	16	0	0	26.0V	0.4A
9	04/11/14 08.01	0	16	0	0	26.4V	0.4A
10	05/11/14 08.01	0	16	0	0	26.2V	0.4A

[\[MAIN PAGE\]](#)

You can see the last 10 results of the function tests.

## 5.2.6 Capacity test results

RESULTS CAPACITY TEST

FUNCTION TEST	DATE SETTING	TEST	DURATION	CAPACITY	BATTERY VOLTAGE :	BATTERY DISCHARGING:
1	00:00:00 00:00	FAILED	00:00	0.000 AH	0.0V	0.0A
2	00:00:00 00:00	FAILED	00:00	0.000 AH	0.0V	0.0A
3	00:00:00 00:00	FAILED	00:00	0.000 AH	0.0V	0.0A
4	00:00:00 00:00	FAILED	00:00	0.000 AH	0.0V	0.0A
5	00:00:00 00:00	FAILED	00:00	0.000 AH	0.0V	0.0A
6	00:00:00 00:00	FAILED	00:00	0.000 AH	0.0V	0.0A
7	00:00:00 00:00	FAILED	00:00	0.000 AH	0.0V	0.0A
8	00:00:00 00:00	FAILED	00:00	0.000 AH	0.0V	0.0A
9	00:00:00 00:00	FAILED	00:00	0.000 AH	0.0V	0.0A
10	00:00:00 00:00	FAILED	00:00	0.000 AH	0.0V	0.0A

[\[MAIN PAGE\]](#)

You can see the last 10 results of the capacity tests.

## 5.2.7 Last autonomies

RESULTS LAST AUTONOMIES

TEST	DATE SETTING	BATTERY CHARGED	DURATION	CAPACITY	BATTERY VOLTAGE	BATTERY DISCHARGING
1	00:00:00 00:00	PARTIAL	000 min	0.000 AH	0.0V	0.0A
2	00:00:00 00:00	PARTIAL	000 min	0.000 AH	0.0V	0.0A
3	00:00:00 00:00	PARTIAL	000 min	0.000 AH	0.0V	0.0A
4	00:00:00 00:00	PARTIAL	000 min	0.000 AH	0.0V	0.0A
5	00:00:00 00:00	PARTIAL	000 min	0.000 AH	0.0V	0.0A
6	00:00:00 00:00	PARTIAL	000 min	0.000 AH	0.0V	0.0A
7	00:00:00 00:00	PARTIAL	000 min	0.000 AH	0.0V	0.0A
8	00:00:00 00:00	PARTIAL	000 min	0.000 AH	0.0V	0.0A
9	00:00:00 00:00	PARTIAL	000 min	0.000 AH	0.0V	0.0A
10	00:00:00 00:00	PARTIAL	000 min	0.000 AH	0.0V	0.0A

[\[MAIN PAGE\]](#)

You can see the latest 10 time periods that the panel has entered emergency mode.



for a safer world!

Date	9/5/2022
Document	923950003_09_010
Document code	923950003_09_010
Page	38 from 39

## 5.2.8 All events

GR-8500, ALL EVENTS

```
001 14/10/14 14:38. DELETE RECORD
002 14/10/14 14:38. START
003 14/10/14 14:39. ENTER TECH MENU
004 14/10/14 14:40. EXIT TECH MENU
005 14/10/14 14:40. ENTER TECH MENU
006 14/10/14 14:41. EXIT TECH MENU
007 14/10/14 15:04. ENTER TECH MENU
008 14/10/14 16:20. EXIT TECH MENU
009 14/10/14 16:20. ENTER TECH MENU
010 15/10/14 08:00. FUNCTION TEST
011 16/10/14 08:00. FUNCTION TEST
012 16/10/14 13:58. EXIT TECH MENU
013 16/10/14 13:58. ENTER TECH MENU
014 17/10/14 08:00. FUNCTION TEST
015 17/10/14 11:54. EXIT TECH MENU
016 17/10/14 15:18. ENTER TECH MENU
```

You can see the latest 250 events of the panel.

## 5.2.9 Network information

You can see the network IP and MAC address of the system.

INFORMATION NETWORK

IP	010.000.001.144
MAC	54:55:58:10:03:F7

[\[MAIN PAGE\]](#)

## 5.2.10 Panels network

NETWORK PANEL

PANEL	INSTALLED	IP ADDRESS	COMMUNICATION	MODE	STATUS	BATTERY	CHARGING	DISCHARGING	LOCATION
1	YES	10.0.1.148	OK	CHARGING	OK	26.3 VDC	00.00 ADC	00.1 ADC	ΠΑΡΑΓΩΓΗ 10Σ ΟΡΟΦ 0
2	NO	0.0.0.0	OK	NO CHARGING	OK	00.0 VDC	00.00 ADC	00.0 ADC	
3	NO	0.0.0.0	OK	NO CHARGING	OK	00.0 VDC	00.00 ADC	00.0 ADC	
4	NO	0.0.0.0	OK	NO CHARGING	OK	00.0 VDC	00.00 ADC	00.0 ADC	
5	NO	0.0.0.0	OK	NO CHARGING	OK	00.0 VDC	00.00 ADC	00.0 ADC	
6	NO	0.0.0.0	OK	NO CHARGING	OK	00.0 VDC	00.00 ADC	00.0 ADC	
7	NO	0.0.0.0	OK	NO CHARGING	OK	00.0 VDC	00.00 ADC	00.0 ADC	
8	NO	0.0.0.0	OK	NO CHARGING	OK	00.0 VDC	00.00 ADC	00.0 ADC	

If there is a network of panels then with this option you can see how many and which panels are installed as well as the most important information for each panel.

  <p><i>for a safer world!</i></p>	Date	9/5/2022
	Document	923950003_09_010
	Document code	923950003_09_010
	Page	39 from 39

## WARRANTY

Olympia Electronics guarantees the quality, condition and operation of the goods. The period of warranty is specified in the official catalogue of Olympia Electronics and also in the technical leaflet, which accompanies each product. This warranty ceases to exist if the buyer does not follow the technical instructions included in official documents given by Olympia Electronics or if the buyer modifies the goods provided or has any repairs or re-setting done by a third party, unless Olympia Electronics has fully agreed to them in writing. Products that have been damaged can be returned to the premises of our company for repair or replacement, as long as the warranty period is valid. Olympia Electronics reserves the right to repair or to replace the returned goods and to or not charge the buyer depending on the reason of deflection. Olympia Electronics reserves the right to charge or not the buyer the transportation cost.

## HEAD OFFICE

72nd km. O.N.R. Thessaloniki-Katerini  
P.C. 60300 P.O. Box 06 Eginio Pierias Greece  
[www.olympia-electronics.gr](http://www.olympia-electronics.gr)  
[info@olympia-electronics.gr](mailto:info@olympia-electronics.gr)